

# A National Power Infrastructure for Charge-on-the-move

Doros Nicolaides  
Department of Engineering  
University of Cambridge  
Cambridge, UK  
dn314@cam.ac.uk

Richard McMahon  
WMG  
University of Warwick  
Coventry, UK

David Cebon  
Department of Engineering  
University of Cambridge  
Cambridge, UK

John Miles  
Department of Engineering  
University of Cambridge  
Cambridge, UK

**Abstract**— It has been generally accepted that electrification of the road transport sector could be a critical step for coping with climate change. Charge-on-the-move is considered to be a critical enabling factor in moving towards electric vehicles and roads. The development of individual charging devices for implementing in-motion charging has been rapid but their integration with the road infrastructure at national scale is still in need of more comprehensive consideration. This work focuses on the challenges of the technology at the level of the system and aims to outline the performance requirements of a national power infrastructure suitable for implementing charge-on-the-move. A UK strategic overview suggests that the installation of a nationwide charging infrastructure of this type is economically feasible. From an estimation of electric vehicles' power requirements in conjunction with UK road traffic data the baseline of the anticipated power demand can be established. Finally, a simulation tool was proposed to investigate the application of dynamic charging and the effects of system design variables on important performance parameters of travelling electric vehicles.

**Keywords**—dynamic charging, electric vehicles, infrastructure, power demand, economics,

## I. INTRODUCTION

It has been generally accepted that decarbonisation of the transport sector is a necessary step towards coping with climate change. The shift towards electric vehicles (EVs) has been identified as one of the most beneficial approaches for achieving this target.

Charge-on-the-move (CoM), also known as dynamic charging, is considered to be a critical enabling factor in moving towards the widespread use of EVs for long distance travel. It is an idea whereby the road infrastructure will be capable of transferring energy to EVs whilst they are on move. The technology offers the opportunity for substantially reducing the installed battery capacity of EVs, thereby eliminating 'range anxiety' and reducing the vehicle purchase price and mass, which are some of the major barriers to increasing use of EVs [1], [2].

The development of inductive power transfer (IPT) charging devices for implementing a CoM infrastructure has advanced significantly over the last few years. A typical IPT system comprises two major subsystems: the road charging unit and the vehicle charging unit. Energy is transferred wirelessly between the two parts of the system when they are

in proximity to each other. High efficiency over 90% can be obtained for static charging applications [3], [4], [5] and similar efficiency is expected to be achieved for dynamic charging as well [6], [7].

However, the integration of IPT road charging units with the road infrastructure on a national scale has not been considered in detail. To this end, the subject of this paper focuses on the challenges of the CoM technology at the level of the system and aims to outline the performance requirements of a national power infrastructure for deployment of CoM. Initially, a UK strategic overview is presented and then the anticipated power demand is estimated. Finally, a simulation tool is proposed to investigate the application of dynamic charging on important performance parameters of EVs, such as mileage range and state of charge of the vehicle's battery (SOC).

The work is focused on the case of the UK which has been legally obliged to reduce substantially its CO<sub>2</sub> emissions by 2050; and therefore, has been keen to adopt innovative strategies for achieving this target.

## II. UK STRATEGIC OVERVIEW

A high-level appraisal of the potential for a national CoM infrastructure in the UK was performed. An epigrammatic technical investigation of the technology was followed by a concise review of the major related considerations, such as standardization, health safety, etc. Sustainable principles introduced by [8] were also used as prompts to evaluate the proposal based on the three aspects of sustainability. Overall, it was shown that a nationwide charging infrastructure of this type could be a critical enabling factor in moving towards EVs and a significant driver for drastic CO<sub>2</sub> emissions reductions in the near future [9].

Solution schemes were developed for implementing a potential CoM infrastructure suitable for electric passenger cars. The approach assumed exploitation of IPT charging devices. Conceptual AC and DC power distribution configurations were developed for establishing the required connections with the electricity supply network (Fig. 1).

20kW IPT devices were considered for the study and it was assumed that energy is transferred to the moving vehicles within the fore-aft misalignment tolerance in the direction of motion without any losses. The values of  $\pm 250\text{mm}$  and  $\pm 600\text{mm}$  were considered for the fore-aft misalignment

tolerance. The number of installed charging devices was determined appropriately to balance out the energy consumption of EVs which was assumed to be constant at 0.20kWh/mile. The solution schemes take into account two different scenarios and in particular, (a) a Current-Conservative scenario assuming 0.20kWh/mile energy consumption plus  $\pm 250$ mm fore-aft misalignment and (b) a Future-Basic scenario with 0.20kWh/mile energy consumption plus  $\pm 600$ mm fore-aft misalignment. Furthermore, new feeder stations and substations were introduced to provide flexibility and circuit protection. The size of stations and distance between equipment were influenced by operational conditions as it is described in [10].

It can be also noticed in Fig. 1 that the power distribution configurations include the adoption of wireless connections between the charging devices and the feeding wire. This approach mitigates the wiring requirements of such a scheme and preserves the main load spreading layer of the road pavement unaffected to a degree [11]. This would be preferable to avoid any compromise of the physical strength and life span of the road. Preliminary studies by [11] have explored the potential for supplying IPT charging devices by capacitive coupling and primary results have suggested a promising potential.

Subsequently, an economic model was developed to examine the financial possibility of the proposed scheme. The key cost drivers of the model include the purchase and installation price of charging devices, price for cables and expenses for cable trenching. Moreover, the cost for feeder stations and sub-stations was considered in the study including expenses for necessary equipment such as circuit breakers, transformers, connection switchgear and protection/metering. In addition, fees for distribution designing and civil engineering were considered and finally, the expenditure to adopt wireless connections was included in the study as well. The model produces the cost per mile relative to class of road and distribution approach; (i) 750V-DC (ii) 11kV-AC, (iii) 11kV-AC plus wireless connections (iv) 3.3kV-AC and (v) 3.3kV-AC plus wireless connections. Furthermore, an additional model was developed to consider lower prices of equipment due to bulk purchases of materials and standardized procedures. This is referred as (c) Future-Basic-Low scenario in TABLE 1. The assumptions and methodology of the model have been reported in [12].

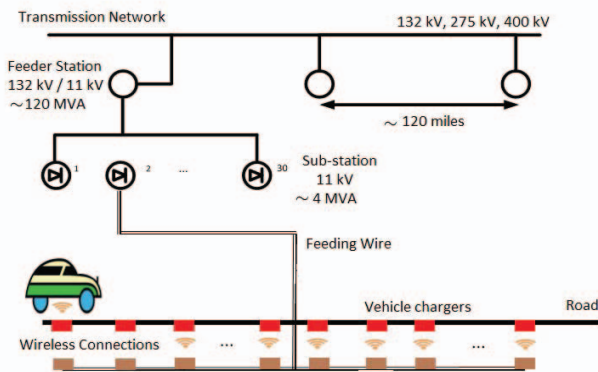

Fig. 1. Conceptual power distribution configuration for CoM (not to scale)

The (iii) 11kV-AC configuration with adoption of wireless connections was found to be the most expensive approach. For that reason, it has been chosen in this study to provide a worst case situation. The results are summarized in TABLE 1 and presented as the cost to install IPT charging devices per mile of road.

The outcomes of the cost model were then combined with road length data [13] and traffic statistics [14] of the UK. The results of the analysis are depicted in Fig. 2. The figure shows the total expenditure to install IPT devices relative to the percentage of electrified car-miles covered in the UK excluding miles driven by freight vehicles, buses, etc.

Based on the (b) Future-Basic scenario, a CoM infrastructure for electrifying 60% of car-miles in the UK (excluding miles travelled on urban roads<sup>1</sup>) would cost £17bn. Such a charging infrastructure involves installation of IPT devices on the motorways of the country. The expenditure to cover 70% of car-miles is £43bn and IPT devices should be introduced to motorways and trunk rural sections of ‘A’ roads. A CoM infrastructure on motorways and both on trunk and principal rural sections of ‘A’ roads would electrify up to 86% of car-miles without exceeding the cost of £110bn. Finally, including IPT devices additionally on rural sections of minor roads, would cover 100% of car-miles excluding car-miles travelled on urban roads where CoM would not be provided.

TABLE 1  
COST PER MILE OF ROAD IN £m FOR THE 11KV-AC PLUS WIRELESS CONNECTIONS POWER DISTRIBUTION CONFIGURATION

	Motorway	Rural
(a) Current-Conservative: 0.20kWh/mile & $\pm 250$ mm	9.5	8.0
(b) Future-Basic: 0.20kWh/mile & $\pm 600$ mm	3.9	3.6
(c) Future-Basic-Low: 0.20kWh/mile & $\pm 600$ mm	3.3	2.9

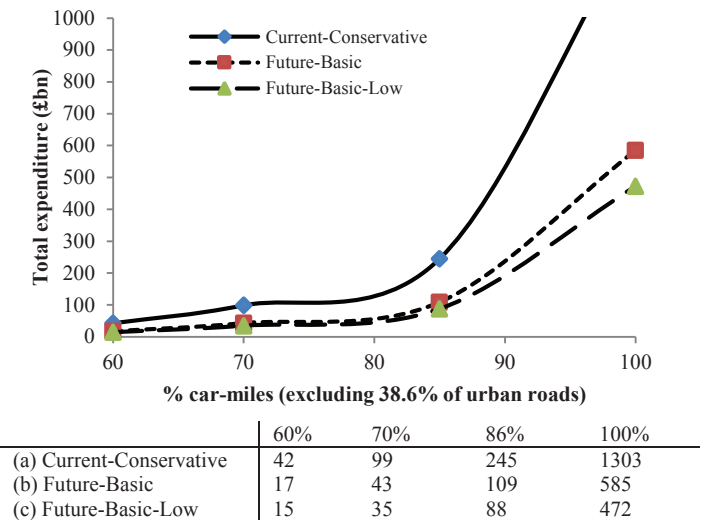

Fig. 2. Total expenditure (£bn) to install IPT devices relative to the percentage of electrified car-miles covered in the UK

<sup>1</sup> Relative short journeys are undertaken in urban roads and therefore, CoM would not be necessary. Furthermore, charging of EVs might be facilitated by a well-developed home and/or public infrastructure within cities boundaries regardless wireless or conductive technologies.

It is highlighted in Fig. 2 that the cost required to electrify the greater part of all car-miles in the country is only a minor fraction of the total cost required to electrify the whole nation for the three scenarios examined. The cost for 86% electrification based on the (b) Future-Basic scenario, is similar to the cost of other national large infrastructure projects; even with the most expensive distribution approach, (iii) 11kV-AC plus wireless connections. For example, similar cost has been reported for the High Speed 2 (HS2) scheme in the UK [15].

Indeed, the impact of a widespread adoption of the CoM technology at today's emission rates in the UK would be to reduce the total UK passenger vehicle emissions from approximately 62MtCO<sub>2</sub> per year to 20MtCO<sub>2</sub> per year<sup>2</sup>. Making allowances for the estimated rate of population increase and changes in travel demand patterns, this would result in UK savings of around 49MtCO<sub>2</sub> per year at 2050<sup>3</sup> and an estimated aggregate saving of 1,600MtCO<sub>2</sub> over the intervening period<sup>4</sup>. Placing these figures in context, it should be noted that the HS2 scheme is expected to result around 3MtCO<sub>2</sub>e savings during the first 60 years of operation [16].

In the long term, CoM will be applicable to most countries of the world and, as a result, these figures could be scaled-up to a global level that would lie in the order of 80,000MtCO<sub>2</sub> per year by 2050<sup>5</sup>. In reality, the real savings are likely to be less than these figures, because the adoption of new low-energy transport systems at scale is unlikely to progress either uniformly or quickly. Nevertheless, simply because road-vehicle related emissions are such large fractions of the emissions footprint of all nations, the potential for global impact is unquestionably enormous.

### III. SYSTEM CHARACTERISATION

Next, the study aims to outline the system performance requirements of a CoM national power infrastructure. Tools and procedures are proposed to calculate the power requirements of EVs and set the baseline of the anticipated power demand on the roads of the UK.

The 'Advanced Vehicle Simulator' (Advisor) was used to estimate the power requirements of EVs. Advisor is an open source software tool that was developed at the National Renewable Energy Laboratory for the US Department of Energy [17]. Its accuracy has been validated by several authors and international labs [18], [19]. The user models the vehicle of interest and investigates the characteristics of the journey over specific drive cycles, such as the required power from the electric motor, the state of charge (SOC) of the on-board battery, etc.

A 'compact car' was firstly modelled and its main vehicle components include a 75kW electric motor, a 30kWh on-board

<sup>2</sup> Assuming 30 million cars; 8,200 average annual mileage range; 157gCO<sub>2</sub>/km for a conventional car [29] and 94gCO<sub>2</sub>/km for an EV (0.2kWh/mile X 400gCO<sub>2</sub>/kWh [30]).

<sup>3</sup> Assuming 35 million cars; 9,400 average mileage range per year; 95gCO<sub>2</sub>/km for a conventional car [9]; 10gCO<sub>2</sub>/km for an EV (0.2kWh/mile X 50gCO<sub>2</sub>/kWh [30]).

<sup>4</sup> Based on a constant 0.5% increase in annualised savings between the numbers calculated for today's norms and those calculated for 2050.

<sup>5</sup> The UK global carbon footprint is 2% [31]

battery and 1,500kg overall mass. The simulation was performed over the 'Artemis Motorway 130' and 'Artemis Rural' drive cycles [20]. The outputs of the simulation for the 'compact car' showed that the average power requirements of EVs are 22kW and 11kW for travelling on motorways and rural sections of road respectively. Urban roads are not included in the study since CoM should focus on longer distance journeys travelled predominantly on motorways and rural sections of road.

The derived figures were combined with UK traffic data in order to estimate the power demands from the power infrastructure. Average daily traffic flow statistics for cars travelling on various roads were obtained from the Department for Transport (DfT) in the UK [14]. Dividing the data with the appropriate speed limit for each road and adding 30% safety margin the average number of cars per mile of road for both directions in the UK can be determined. A speed limit of 70mph and 60mph applies for cars travelling on motorways and rural sections of road respectively [21]. The results for each region of the UK are stated in TABLE 2 and classified into trunk (TR) and principal (PR) sections. Similar methodology was followed for estimating the power demands from a possible electrified road freight transport network in the UK [22].

The average power demand per mile of road can be determined. The analysis takes into account current traffic statistics and 100% uptake of EVs for sizing the infrastructure for a potential CoM system. It should be noted that only the motorways and rural sections of 'A' roads are included in the study as it was described earlier. As an illustration, the average density of cars per mile of motorway in London is depicted with the dashed line in Fig. 3. During the peak hours of commuting there are around 110 passenger cars per mile of road and the average power required to propel this number of EVs is approximately 2.4MW per mile. In a similar way, the number of EVs and power required on trunk rural sections of 'A' roads in South East during peak hours are 54 and 594kW respectively. Indeed, trunk motorways of London and rural 'A' sections of South East have the highest density of EVs per mile of road and selection of alternative regions leads to lower power demand per mile for both road types.

TABLE 2  
AVERAGE NUMBER OF PASSENGER CARS PER MILE OF ROAD FOR BOTH DIRECTIONS IN THE UK BY REGION IN 2013

		Motorway		Rural 'A'	
		TR	PR	TR	PR
England	North East	33	49	19	7
	North West	46	29	13	6
	Yorkshire & the Humber	36	37	20	7
	East Midlands	53	0	23	7
	West Midlands	46	54	17	6
	East of England	53	0	24	9
	London	59	0	0	19
	South East	56	48	29	9
	South West	44	0	16	6
	Wales	40	0	8	4
Scotland	25	0	6	2	

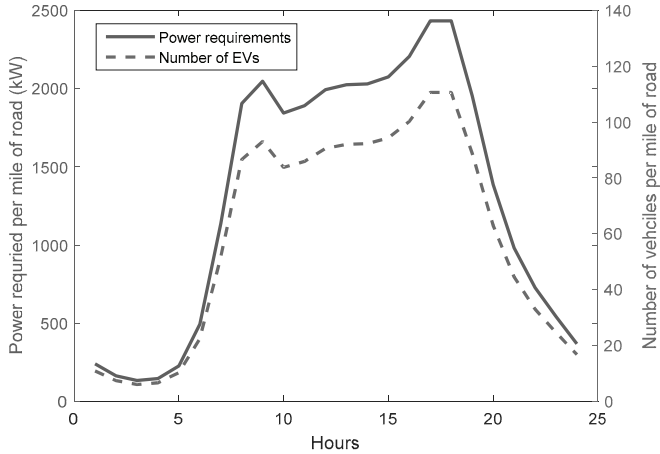

Fig. 3. Power required and density of EVs on motorways of London by hour of day

TABLE 3  
POWER DEMAND IN GW FOR A CoM INFRASTRUCTURE

	Motorway	Rural 'A'	Total
England	3.7	2.8	6.5
Wales	0.1	0.3	0.4
Scotland	0.3	0.4	0.7
<i>Total</i>	<i>4.1</i>	<i>3.5</i>	<i>7.6</i>

The analysis was conducted for all areas of the UK. The derived figures were joint with road length data [13] and the overall power demand for such a charging infrastructure was estimated. The results are summarised in TABLE 3 and it can be noticed that for 86% electrification of car-miles in the UK (excluding miles driven on urban roads), an additional power load of 7.6GW has to be distributed along the motorways and all rural sections of 'A' roads.

The new power demand represents an additional load of 14.4% based on the expected 2016/2017 winter demand (52.7GW) [23] and goes largely beyond the capacity margin of the electricity system (5GW) in the UK [24]. Nevertheless, various authorities have already embarked on plans to upgrade the electricity supply network mainly due to the shifting to EVs and electric heating. The anticipated installed generating capacity in the UK is estimated to be around 130GW by 2050 [25] thus allowing a considerable capacity margin for CoM. Furthermore, the Electricity Networks Strategy Group has defined pathways to reinforce the transmission network of the UK [26] and finally, various distribution companies have already embarked on upgrade projects to deal with the increased future demand [27], [28].

#### IV. CHARGING SIMULATION TOOL

Subsequently, a simulation tool was developed to investigate the application of dynamic charging and the effects of system design variables on important performance parameters, such as the mileage range and the state of charge of the battery (SOC). The tool was also used for exploring the prospects of road freight electrification in [22].

The user determines (i) the type of EV (ii) the capacity of the on-board battery (iii) the driving cycle and finally, (iv) the specifications of the dynamic charging system to be investigated: the distance between consecutive chargers, the charging segment length and the power rating of the charger.

The simulation outcomes for a 'compact car' travelling on motorway, 45% of which is online (4.5m charging segment length every 10m) at 50kW are summarised in Fig. 4. The first graph of the figure shows the drive cycle of the simulation run which is the 'Artemis motorway 130'. Fig. 4(b) shows the power required from the electric motor and Fig. 4(c) shows the (i) energy requested (ii) energy received and (iii) energy consumed from the vehicle under investigation throughout the journey. The SOC including/not including CoM infrastructure is presented in the fourth graph of Fig. 4.

The charging simulation produces additional outputs which are listed in the bottom of Fig. 4: (i) the battery capacity of the vehicle under investigation, (ii) the final SOC without any charging facilities, (iii) the final SOC with CoM infrastructure, (iv) the total energy requested (used by the electric motor) in the simulation run, (v) the energy received from the CoM system, (vi) the energy consumed during the whole journey, (vii) the average speed of the vehicle, (viii) the average consumption of the vehicle, and finally (ix) the 'Mean Effective Charging Rate' (MECR), denoted  $\Psi$ , which is the energy delivered by the charging system per mile along the road.

The simulation tool is built on top of 'Advisor' which produces the figures of speed, power and energy according to the parameters of the vehicle and drive cycle under investigation. The energy received and the new SOC of the vehicle are influenced by the specifications of the charging devices. The longer the charging segment length and/or the power rating, the higher the amount of energy received. In contrast, the greater the distance between consecutive chargers and/or the lower the nominal power rating, the lower the received energy. It could be noticed in Fig. 4(c) that the energy requested by the electric motor has a continuous trend throughout the journey; whereas the energy received, and the consequent energy consumed get discrete values. The charging devices are installed sporadically on the roads and energy is received when the vehicle is located above a charging device. The upper value of the transferred energy is influenced by the power rating of the charging device and the speed of the vehicle since energy is the product of power and time. The charging model assumes instantaneous operation of chargers and 100% energy transfer efficiency.

Fig. 5 shows the motorway SOC of the modelled 'compact car' for various MECR. It can be noticed that EVs would have a fully depleted battery on battery power alone solution after 85 miles on motorways. Whereas with a dynamic charging system capable of delivering  $\Psi$  equals 0.36kWh/mile they could run indefinitely.

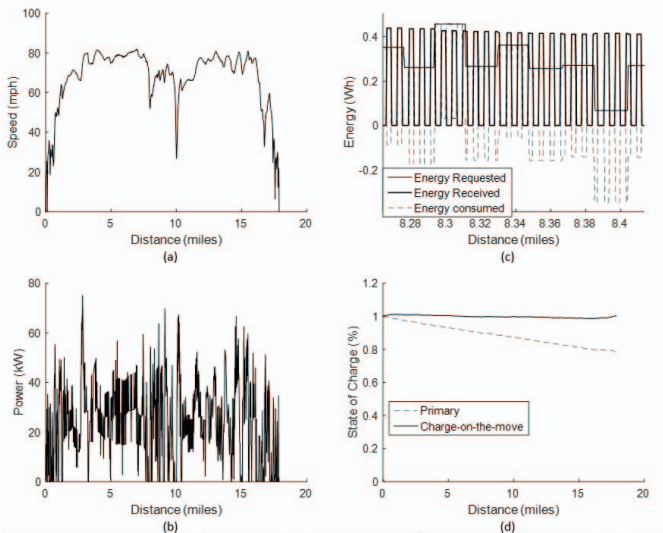

Fig. 4. Outputs of a simulation for a 'compact car' travelling over the 'Artemis motorway' drive cycle. (a) Requested speed of vehicle (b) Requested power from electric motor (c) Energy plots (d) State of charge history

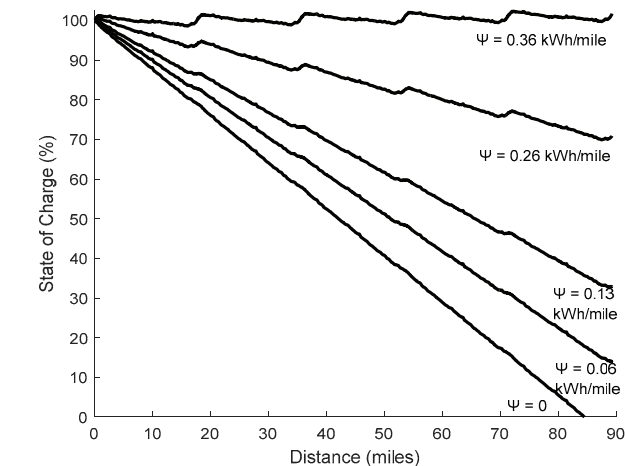
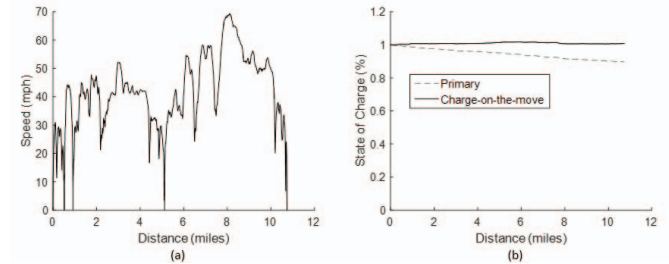

Fig. 5. Motorway SOC of 'compact car' for various levels of MECR

For the IPT technology the necessary MECR of 0.36kWh/mile is translated into 22kW power transfer per metre<sup>6</sup>. Multiple combinations between charging segment length, nominal power rating of the charger and distance between consecutive chargers might be decided to achieve the needed MECR. One possible configuration, is the installation of 4.5m long IPT chargers at 50kW every 10m. This configuration takes into account that the average length of a car is 5m and the minimum gap between two cars at motorways queues is 10m [6]; hence, none charging device would transmit energy to multiple EVs at the same time.

<sup>6</sup> The average speed of the vehicle following the 'Artemis motorway' drive cycle, shown in Fig. 4a is 60mph. The power required is calculated as  $P=0.36\text{kWh/mile} (\Psi) \times 60\text{mph (average speed)} = 22\text{kW}$



Battery Capacity (kWh)	30	Energy Requested (kWh)	3	Average speed (mph)	36
Final SOC (%)	0.9	Energy Received (kWh)	3	Aver. consumption (kWh/mile)	0.29
Final SOC with CoM (%)	1	Energy Consumed (kWh)	0	$\Psi$ (kWh/mile)	0.29

Fig. 6. Outputs of a simulation for a 'compact car' travelling over the 'Artemis rural' drive cycle (a) Requested speed (b) State of charge history

Similar analysis was conducted for the rural sections of roads and the outputs of the simulation are presented in Fig. 6. The required MECR for these journeys is 0.29kWh/mile. Using the same IPT chargers assumed earlier for motorways (4.5m charging segment length at 50kW) a CoM infrastructure on rural sections of roads should have a device every 20m.

## V. CONCLUSIONS

The UK strategic overview for the CoM proposal has revealed a great potential for electrification of the passenger road transport system. The development of potential approaches coupled with the economic appraisal has suggested that a nationwide infrastructure of this type is economically feasible. The total expenditure to electrify up to 86% of all car-miles in the country does not exceed £110bn, based on the most expensive distribution approach, which is a similar figure to the cost of other national large infrastructure projects in the region.

The average power requirements of EVs were combined with the number of vehicles on various roads, in order to estimate the total power demand needed from the power infrastructure. Indeed, 2.4MW and 594kW per mile is required during the peak hours for EVs travelling on the motorways and rural sections of 'A' roads respectively. Furthermore, the power demand of the UK is expected to be augmented by 7.6GW and finally, a charging simulation tool was proposed to investigate the application of dynamic charging. It was shown that a charging infrastructure capable of transferring 0.36kWh/mile and 0.29kWh/mile would preserve 100% SOC of the on-board battery for EVs travelling on motorways and rural sections of 'A' roads. A possible CoM layout should include (i) 4.5m charging segment length, (ii) power rating at 50kW and (iii) distance between consecutive chargers at 10m and 20m for motorways and rural sections of road respectively.

## REFERENCES

- [1] S. Beggs, S. Cardell, and J. Hausman, "Assessing the potential demand for electric cars," *J. Econom.*, vol. 17, no. 1, pp. 1–19, Sep. 1981.
- [2] J. Reed, "Buyers loath to pay more for electric cars," *Financial Times*, 2010. [Online]. Available: <http://www.ft.com/cms/s/0/acc0a646-c405-11df-b827-00144feab49a.html#axzz4GmVVbS5T>.
- [3] J. M. Miller, P. T. Jones, J.-M. Li, and O. C. Onar, "ORNL Experience and Challenges Facing Dynamic Wireless Power Charging of EV's," *IEEE Circuits Syst. Mag.*, vol. 15, no. 2, pp. 40–53, Jan. 2015.

- [4] J. T. Boys and G. A. Covic, "The Inductive Power Transfer Story at the University of Auckland," *IEEE Circuits Syst. Mag.*, vol. 15, no. 2, pp. 6–27, Jan. 2015.
- [5] T. M. Fisher, K. B. Farley, Y. Gao, H. Bai, and Z. T. H. Tse, "Electric vehicle wireless charging technology: a state-of-the-art review of magnetic coupling systems," *Wirel. Power Transf.*, pp. 1–10, Sep. 2014.
- [6] D. Naberezhnykh, N. Reed, F. Ognissanto, T. Theodoropoulos, and H. Bludszweit, "Operational requirements for dynamic wireless power transfer systems for electric vehicles," in *2014 IEEE International Electric Vehicle Conference (IEVC)*, 2014, pp. 1–8.
- [7] X. Zhang, Z. Yuan, Q. Yang, Y. Li, J. Zhu, and Y. Li, "Coil Design and Efficiency Analysis for Dynamic Wireless Charging System for Electric Vehicles," *IEEE Trans. Magn.*, vol. 52, no. 7, pp. 1–4, Jul. 2016.
- [8] C. M. Ainger and R. A. Fenner, *Sustainable Infrastructure: Principles into Practice*. UK: ICE Publishing, 2013.
- [9] D. Nicolaides and J. Miles, "Wireless Electric Charge-on-the-move: A sustainability appraisal of the potential for the UK transport application," *J. Multidiscip. Eng. Sci. Technol.*, vol. 2, no. 8, pp. 2238–2246, 2015.
- [10] D. Nicolaides, "Wireless Electric Charge-on-the-move: An appraisal of the potential for the UK Transport application," MPhil thesis, Dept. Engineering, University of Cambridge, Cambridge, UK, 2014.
- [11] D. Nicolaides, J. Miles, and R. McMahon, "The potential for supplying charging coils by capacitive coupling for charge-on-the-move," submitted to *IEEE Trans. on Intelligent Transportation Systems*.
- [12] D. Nicolaides and J. Miles, "Wireless Electric Charge-On-The-Move: An Economic Appraisal of the Potential for the UK Transport Application," in *International Conference on Transportation and Civil Engineering*, 2015, pp. 53–59.
- [13] Department for Transport, "Road length in Great Britain: 2014," National Statistics, 2015. [Online]. Available: <https://www.gov.uk/government/statistics/road-lengths-in-great-britain-2014>.
- [14] Department for Transport, "Traffic counts," 2014. [Online]. Available: <http://www.dft.gov.uk/traffic-counts/index.php>.
- [15] M. Leftly, "HS2: Cost of London-to-Birmingham leg of proposed new railway a third higher than previously estimated," *Independent*, 2015. [Online]. Available: <http://www.independent.co.uk/news/uk/politics/hs2-cost-of-london-to-birmingham-leg-of-proposed-new-railway-a-third-higher-than-previously-estimated>.
- [16] UK Parliament, "HS2 and the environment," *Environmental Audit*, 2014. [Online]. Available: <http://www.publications.parliament.uk/pa/cm201314/cmselect/cmenvau/d/1076/107608.htm>.
- [17] A. Brooker, K. Haraldsson, T. Hendricks, V. Johnson, K. Kenneth, B. Kramer, T. Markel, M. O'Keefe, S. Sprik, K. Wipke, and M. Zolot, "ADVISOR Advanced Vehicle Simulator," NREL, 2013. [Online]. Available: <http://adv-vehicle-sim.sourceforge.net/>.
- [18] R. D. Senger, "Validation of ADVISOR as a Simulation Tool for a Series Hybrid Electric Vehicle Using the Virginia Tech FutureCar Lumina," Virginia Tech, 1997.
- [19] K. B. Wipke, M. R. Cuddy, and S. D. Burch, "ADVISOR 2.1: a user-friendly advanced powertrain simulation using a combined backward/forward approach," *IEEE Trans. Veh. Technol.*, vol. 48, no. 6, pp. 1751–1761, 1999.
- [20] T. Barlow, S. Latham, I. McCrae, and P. Boulter, "A reference book of driving cycles for use in the measurement of road vehicle emissions," 2009.
- [21] GOV.UK, "Speed limits," 2016. [Online]. Available: <https://www.gov.uk/speed-limits>.
- [22] D. Nicolaides, D. Cebon, and J. Miles, "Prospects for electrification of freight transportation," submitted to *IEEE Systems Journal*.
- [23] National Grid, "Winter Consultation 2016," Warwick, UK, 2016.
- [24] Royal Academy of Engineering, "GB electricity capacity margin," 2013.
- [25] G. Ault, D. Frame, N. Hughes, and N. Strachan, "Electricity Network Scenarios for Great Britain in 2050," 2008.
- [26] ENSG, "Our Electricity Transmission Network: A vision for 2020," 2012.
- [27] Northwest Electricity, "Strategic Direction Statement," 2013.
- [28] UK Power Networks, "Business plan (2015 to 2023)," 2012.
- [29] Department for Transport, "Vehicle Licensing Statistics," 2016.
- [30] DECC, "Updated energy and emissions projections," Department of Energy & Climate Change, 2013.
- [31] Union of Concerned Scientists, "Each Country's Share of CO2 Emissions," *Global Warming*, 2014.