

Flow Synthesis of Cyclobutanones via [2+2] Cycloaddition of Keteneiminium Salts and Ethylene Gas

Claudio Battilocchio, Grazia Iannucci, Shiyi Wang, Edouard Godineau, Amandine Kolleth Krieger, Alain De Mesmaeker, and Steven V. Ley*

Innovative Technology Centre, Department of Chemistry, University of Cambridge, Lensfield Road, CB2 1EW, UK;
Syngenta Crop Protection AG, Crop Protection Research, Schaffhauserstrasse 101, CH-4332, Switzerland

Supporting Information Placeholder

TABLE OF CONTENTS

1. General Information.....	2
2. General procedure for the preparation of the amides	3
2.1. Characterization data of the amides	3
3. Flow Synthesis of the cyclobutanones	10
3.1. Characterization data of the cyclobutanones	12
References	19

1. General Information

Unless stated otherwise, reagents were obtained from commercial sources and used without purification. New compounds have been fully characterized. NMR characterization was performed on reported ones. ^1H NMR spectra were recorded on Bruker Avance DPX-600 (600 MHz), with the residual solvent peak as the internal reference ($\text{CDCl}_3 = 7.26$ ppm). ^1H resonances are reported to the nearest 0.01 ppm. ^{13}C -NMR spectra were recorded on the same spectrometer with proton decoupling, with the solvent peak as the internal reference ($\text{CDCl}_3 = 77.00$ ppm). All ^{13}C resonances are reported to the nearest 0.01 ppm. The multiplicity of ^1H signals are indicated as: s = singlet, d = doublet, dd = doublet of doublets, ddd = doublet of doublets of doublets, t = triplet, q = quadruplet, sext = sextet, m = multiplet, br = broad, or combinations of thereof. Coupling constants (J) are quoted in Hz and reported to the nearest 0.1 Hz. Where appropriate, measures of the same coupling constant are averaged. The removal of solvent under reduced pressure was carried out on a standard rotary evaporator. Infrared spectra were recorded on a Perkin-Elmer Spectrum RX One FT-IR ATR (Attenuated Total Reflectance) spectrometer. The samples were prepared as thin films deposited on the ATR, unless otherwise specified. Only structurally important absorptions are quoted. Absorption maxima (ν_{max}) are reported in wavenumbers (cm^{-1}). All gas-flow reactions were performed on a Vapourtec R2+/R4 module¹ and using a tube-in-tube reactor to introduce gases into a continuous flow stream. For the design of the tube-in-tube reactor see previous publications.²

2. General procedure for the preparation of the amides

To a solution of carboxylic acid (1 mmol) in anhydrous CH_2Cl_2 (3 ml) were added bis-allylamine (1.1 mmol), *N*-(3-dimethylaminopropyl)-*N*-ethylcarbodiimide (EDC) (1.5 mmol) and 4-(dimethylamino)pyridine (DMAP) (0.2 mmol).³ The resulting solution was stirred overnight at room temperature, then diluted with CH_2Cl_2 (5 ml) and washed with 10 % HCl (3 x 10 ml). The combined organic layer was washed with brine, dried over anhydrous MgSO_4 and filtered. The solvent was removed *in vacuo* and the crude residue was purified by silica gel column chromatography using Hex/AcOEt (1:1) as eluent.

2.1. Characterization data of the amides

N,N-diallyl-2-(*p*-tolyl)acetamide

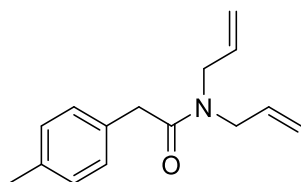

Yellowish oil, 85 % yield. **FT-IR** (ν_{max} , cm^{-1}) 1639. **¹H-NMR** (600 MHz, CDCl_3) δ 7.14 (dd, $J = 16.4, 8.1$ Hz, 4H), 5.85 – 5.63 (m, 2H), 5.15 (dddd, $J = 29.8, 18.6, 13.7, 1.2$ Hz, 4H), 4.00 (d, $J = 6.0$ Hz, 2H), 3.86 (d, $J = 5.0$ Hz, 2H), 3.67 (s, 2H), 2.33 (s, 3H). **¹³C-NMR** (151 MHz, CDCl_3) δ 171.17, 136.28, 133.18, 132.94, 132.04, 129.33, 128.59, 117.23, 116.76, 49.42, 47.84, 40.36, 21.04.

N,N-diallyl-2-(3-(trifluoromethyl)phenyl)acetamide

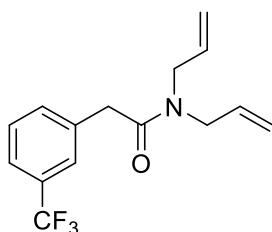

Yellowish oil, 85 % yield. **FT-IR** (ν_{max} , cm^{-1}) 1639. **¹H-NMR** (600 MHz, CDCl_3) δ 7.51 – 7.37 (m, 2H), 5.81 – 5.65 (m, 1H), 5.29 – 5.00 (m, 2H), 3.99 (d, $J = 5.9$ Hz, 1H), 3.88 (d, $J = 4.4$ Hz, 1H), 3.72 (s, 1H). **¹³C-NMR** (151 MHz, CDCl_3) δ 170.11, 136.16, 132.87, 132.61, 130.69 (q, $J = 32.0$ Hz), 128.89, 125.85 (q, $J = 3.75$ Hz), 124.99, 123.60 (m), 123.19, 117.44, 116.76, 49.40, 48.14, 39.87.

N,N-diallyl-2-(thiophen-3-yl)acetamide

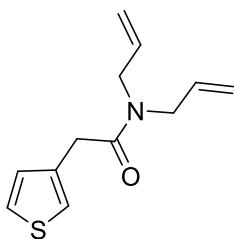

Yellowish oil, 72 % yield. **FT-IR** (ν_{\max} , cm^{-1}) 1634. **$^1\text{H-NMR}$** (600 MHz, CDCl_3) δ 7.16 (dd, $J = 4.9, 3.0$ Hz, 1H), 7.01 – 6.95 (m, 1H), 6.93 (d, $J = 5.0$ Hz, 1H), 5.73 – 5.53 (m, 2H), 5.15 – 4.93 (m, 4H), 3.90 (d, $J = 6.1$ Hz, 2H), 3.78 (d, $J = 5.0$ Hz, 2H), 3.60 (s, 2H). **$^{13}\text{C-NMR}$** (151 MHz, CDCl_3) δ 170.54, 134.91, 133.02, 132.87, 128.26, 125.69, 121.98, 117.25, 116.69, 49.48, 47.83, 35.37.

N,N-diallyl-2-(3,4-dimethoxyphenyl)acetamide

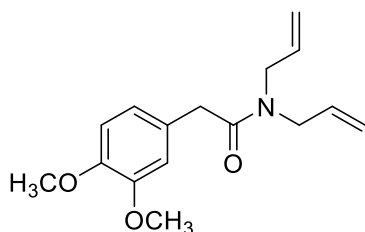

Yellowish oil, 85 % yield. **FT-IR** (ν_{\max} , cm^{-1}) 1634 (C=O amide). **$^1\text{H-NMR}$** (600 MHz, CDCl_3) δ 6.81 (m, 2H), 6.76 (m, 1H), 5.81 – 5.63 (m, 2H), 5.23 – 5.04 (m, 4H), 3.99 (d, $J = 5.8$ Hz, 2H), 3.86 (bs, 8H), 3.64 (s, 2H). **$^{13}\text{C-NMR}$** (151 MHz, CDCl_3) δ 171.18, 149.06, 147.89, 133.06, 132.90, 127.61, 120.82, 117.17, 116.79, 111.79, 111.25, 55.88, 55.83, 49.43, 47.82, 40.32

N,N-diallyl-2-(benzo[d][1,3]dioxol-5-yl)acetamide

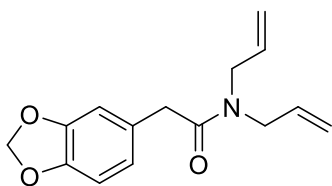

Yellowish oil, 80 % yield. **FT-IR** (ν_{\max} , cm^{-1}) 1636. **$^1\text{H-NMR}$** (600 MHz, CDCl_3) δ 6.80 – 6.68 (m, 2H), 6.66 (d, $J = 8.0$ Hz, 1H), 5.90 (s, 2H), 5.80 – 5.65 (m, 2H), 5.24 – 5.03 (m, 4H), 3.98 (d, $J = 6.0$ Hz, 2H), 3.86 (d, $J = 4.8$ Hz, 2H), 3.59 (s, 2H). **$^{13}\text{C-NMR}$** (151 MHz, CDCl_3) δ 171.11, 147.83, 146.42, 133.06, 132.83, 128.71, 121.80, 117.35, 116.81, 109.29, 108.27, 100.94, 49.39, 47.97, 40.19.

N,N-diallyl-2-(*p*-methoxyphenyl)acetamide

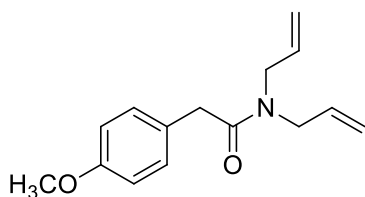

Yellowish oil, 70% yield. **FT-IR** (ν_{\max} , cm^{-1}) 1635. **$^1\text{H-NMR}$** (600 MHz, CDCl_3) δ 7.11 (d, $J = 8.7$ Hz, 2H), 6.78 (d, $J = 8.8$ Hz, 2H), 5.75 – 5.56 (m, 2H), 5.20 – 4.94 (m, 4H), 3.92 (d, $J = 6.0$ Hz, 2H), 3.79 (d, $J = 5.0$ Hz, 2H), 3.69 (s, 3H), 3.57 (s, 2H). **$^{13}\text{C-NMR}$** (151 MHz, CDCl_3) δ 171.19, 158.40, 133.14, 132.96, 129.74, 127.12, 117.12, 116.65, 113.98, 55.11, 49.36, 47.77, 39.68.

2,2'-(1,4-phenylene)bis(*N,N*-diallylacetamide)

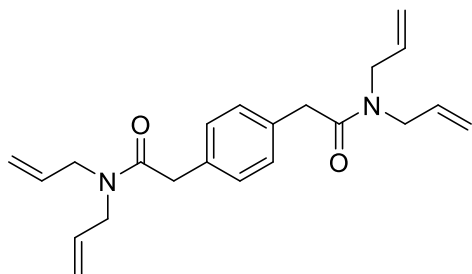

Yellowish solid, 83 %. **FT-IR** (ν_{\max} , cm^{-1}) 1652, 1634. **$^1\text{H-NMR}$** (600 MHz, CDCl_3) δ 7.22 (s, 4H), 5.81 – 5.65 (m, 4H), 5.26 – 5.06 (m, 8H), 4.00 (d, $J = 5.9$ Hz, 4H), 3.88 – 3.84 (m, 4H), 3.69 (s, 4H). **$^{13}\text{C-NMR}$** (151 MHz, CDCl_3) δ 170.94, 133.63, 133.11, 132.84, 129.04, 117.33, 116.81, 49.43, 47.90, 40.32.

N,N-diallyl-2-(5-methylbenzofuran-3-yl)acetamide

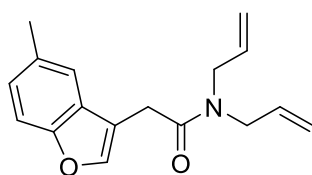

Yellowish oil, 73 % yield. **FT-IR** (ν_{\max} , cm^{-1}) 1637. **$^1\text{H-NMR}$** (600 MHz, CDCl_3) δ 8.20 – 8.11 (m, 2H), 7.42 (d, $J = 8.6$ Hz, 2H), 5.85 – 5.68 (m, 2H), 5.30 – 5.05 (m, 4H), 4.01 (s, 2H), 3.94 – 3.89 (m, 2H), 3.79 (s, 2H). **$^{13}\text{C-NMR}$** (151 MHz, CDCl_3) δ 169.47, 146.92, 142.85, 132.76, 132.53, 130.17, 123.61, 117.78, 116.99, 49.47, 48.36, 39.89.

N,N-diallyl-2-(2-chlorophenyl)acetamide

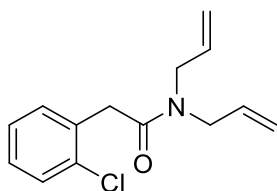

Yellowish oil, 72 % yield. **FT-IR** (ν_{\max} , cm^{-1}) 1639. **$^1\text{H-NMR}$** (600 MHz, CDCl_3) δ 7.39 (d, $J = 1.6$ Hz, 1H), 7.38 (d, $J = 1.8$ Hz, 1H), 7.27 – 7.20 (m, 2H), 5.85 – 5.73 (m, 2H), 5.29 – 5.11 (m, 4H), 4.05 (d, $J = 6.0$ Hz, 2H), 3.96 – 3.90 (m, 2H), 3.82 (s, 2H). **$^{13}\text{C-NMR}$** (151 MHz, CDCl_3) δ 170.09, 134.09, 133.48, 133.08, 132.58, 130.92, 129.40, 128.35, 126.97, 117.51, 116.89, 49.45, 48.15, 37.99.

N,N-diallyl-2-(4-cyanophenyl)acetamide

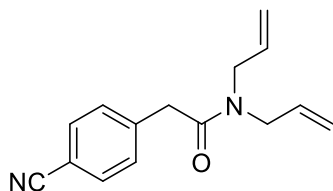

Yellowish oil, 78 % yield. **FT-IR** (ν_{\max} , cm^{-1}) 2227, 1636. **$^1\text{H-NMR}$** (600 MHz, CDCl_3) δ 7.59 (d, $J = 7.9$ Hz, 2H), 7.36 (d, $J = 7.8$ Hz, 2H), 5.82 – 5.69 (m, 2H), 5.28 – 5.05 (m, 4H), 3.99 (d, $J = 5.4$ Hz, 2H), 3.89 (s, 2H), 3.73 (s, 2H). **$^{13}\text{C-NMR}$** (151 MHz, CDCl_3) δ 169.65, 140.74, 132.79, 132.54, 132.22, 130.05, 118.80, 117.73, 116.97, 110.72, 49.45, 48.30, 40.17.

N,N-diallyl-2-(4-nitrophenyl)acetamide

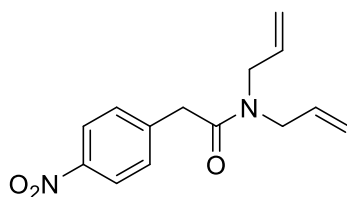

Yellowish oil, 73 % yield. **FT-IR** (ν_{\max} , cm^{-1}) 1637. **$^1\text{H-NMR}$** (600 MHz, CDCl_3) δ 8.20 – 8.11 (m, 2H), 7.42 (d, $J = 8.6$ Hz, 2H), 5.85 – 5.68 (m, 2H), 5.30 – 5.05 (m, 4H), 4.01 (s, 2H), 3.94 – 3.89 (m, 2H), 3.79 (s, 2H). **$^{13}\text{C-NMR}$** (151 MHz, CDCl_3) δ 169.47, 146.92, 142.85, 132.76, 132.53, 130.17, 123.61, 117.78, 116.99, 49.47, 48.36, 39.89.

Ethyl 10-(diallylamino)-10-oxodecanoate

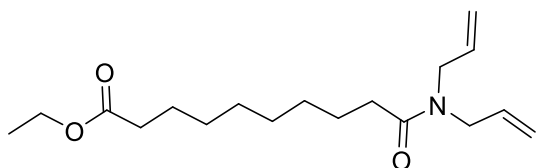

Yellowish oil, 71% yield. **FT-IR** (ν_{\max} , cm^{-1}) 1641 cm^{-1} . **$^1\text{H-NMR}$** (600 MHz, CDCl_3) δ 5.81 – 5.72 (m, 2H), 5.25 – 5.10 (m, 4H), 4.14 (q, $J = 7.1$ Hz, 2H), 4.00 (d, $J = 5.9$ Hz, 2H), 3.88 (dd, $J = 2.9$, 1.8 Hz, 2H), 2.30 (dt, $J = 10.9$, 7.6 Hz, 4H), 1.66 – 1.58 (m, 5H), 1.28 (dd, $J = 21.8$, 14.7 Hz, 11H). **$^{13}\text{C-NMR}$** (151 MHz, CDCl_3) δ 173.79, 173.06, 133.34, 132.89, 116.98, 116.35, 60.07, 49.03, 47.71, 34.25, 32.88, 29.27, 29.18, 29.04, 28.99, 25.21, 24.86, 14.19.

N,N-diallyl-11-bromoundecanamide

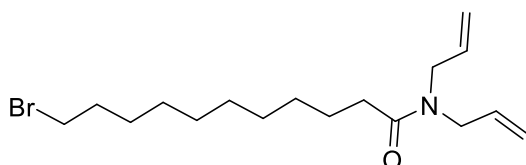

Amorphous white solid, 83% yield. **FT-IR** (ν_{\max} , cm^{-1}) 1653 cm^{-1} . **$^1\text{H-NMR}$** (600 MHz, CDCl_3) δ 5.83 – 5.73 (m, 1H), 5.26 – 5.09 (m, 2H), 4.00 (d, $J = 5.9$ Hz, 1H), 3.89 (d, $J = 4.7$ Hz, 1H), 3.42 (t, $J = 6.9$ Hz, 1H), 2.35 – 2.30 (m, 1H), 1.91 – 1.82 (m, 1H), 1.65 (dd, $J = 14.6$, 7.2 Hz, 1H), 1.43 (dd, $J = 14.6$, 7.1 Hz, 1H), 1.29 (d, $J = 13.3$ Hz, 5H). **$^{13}\text{C-NMR}$** (151 MHz, CDCl_3) δ 173.16, 133.43, 132.95, 117.07, 116.46, 49.09, 47.77, 34.18, 33.02, 32.81, 29.42, 29.41, 29.39, 29.37, 28.74, 28.15, 25.32.

N,N-diallyloctanamide

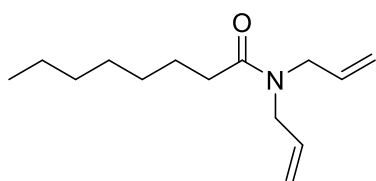

Yellowish oil, 48 % yield. **FT-IR** (ν_{\max} , cm^{-1}) 1641. **$^1\text{H-NMR}$** (600 MHz, CDCl_3) δ 5.75 – 5.63 (m, 2H), 5.16 – 5.01 (m, 4H), 3.91 (d, $J = 6.0$ Hz, 2H), 3.83 – 3.78 (m, 2H), 2.29 – 2.18 (m, 2H), 1.62 – 1.53 (m, 2H), 1.28 – 1.15 (m, 8H), 0.80 (t, $J = 6.9$ Hz, 3H). **$^{13}\text{C-NMR}$** (151 MHz, CDCl_3) δ 173.11, 133.35, 132.89, 116.95, 116.34, 49.03, 47.69, 32.93, 31.64, 29.32, 29.06, 25.27, 22.55, 14.03.

N,N-diallylcyclohexanecarboxamide

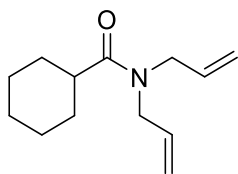

Colorless oil, 40 % yield. **FT-IR** (ν_{\max} , cm^{-1}) 1630. **$^1\text{H-NMR}$** (600 MHz, CDCl_3) δ 5.78 (m, 2H), 5.30 – 5.01 (m, 4H), 3.97 (s, 2H), 3.90 (s, 2H), 2.50 – 2.35 (m, 1H), 1.87 – 1.45 (m, 7H), 1.26 (s, 3H). **$^{13}\text{C-NMR}$** (151 MHz, CDCl_3) δ 176.34, 133.56, 116.75, 116.35, 48.93, 47.70, 40.82, 29.64, 25.81, 25.77.

N,N-diallylpent-4-ynamide

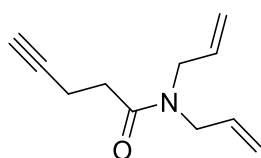

Yellowish oil, 53 % yield. **FT-IR** (ν_{\max} , cm^{-1}) 1637. **$^1\text{H-NMR}$** (600 MHz, CDCl_3) δ 5.81 – 5.63 (m, 2H), 5.35 – 4.95 (m, 4H), 3.96 (d, $J = 6.4$ Hz, 2H), 3.91 – 3.79 (m, 2H), 2.59 – 2.43 (m, 4H), 1.98 – 1.92 (m, 1H). **$^{13}\text{C-NMR}$** (151 MHz, CDCl_3) δ 170.85, 133.08, 132.49, 117.36, 116.60, 83.51, 68.71, 48.91, 48.03, 31.97, 14.51.

N,N-diallyl-3-phenylpropanamide

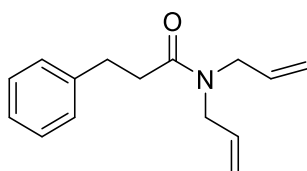

Yellowish oil, 86 % yield. **FT-IR** (ν_{\max} , cm^{-1}) 1637. **$^1\text{H-NMR}$** (600 MHz, CDCl_3) δ 7.26 (t, $J = 7.5$ Hz, 2H), 7.23 – 7.15 (m, 3H), 5.79 – 5.64 (m, 2H), 5.20 – 5.03 (m, 4H), 3.98 (d, $J = 6.1$ Hz, 2H), 3.81 – 3.75 (m, 2H), 3.01 – 2.94 (m, 2H), 2.65 – 2.57 (m, 2H). **$^{13}\text{C-NMR}$** (151 MHz, CDCl_3) δ 172.13, 141.31, 133.29, 132.82, 128.43, 126.08, 117.19, 116.47, 49.07, 48.01, 34.86, 31.49.

N,N-diallyl-4-(pyren-1-yl)butanamide

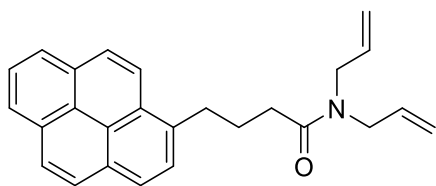

Yellowish oil, 60% yield. **FT-IR** (ν_{\max} , cm^{-1}) 1635. **$^1\text{H-NMR}$** (600 MHz, CDCl_3) δ 8.37 (d, $J = 9.2$ Hz, 1H), 8.17 (t, $J = 6.7$ Hz, 2H), 8.12 (d, $J = 3.5$ Hz, 1H), 8.11 (d, $J = 2.0$ Hz, 1H), 8.06 – 7.97 (m, 3H), 7.88 (d, $J = 7.7$ Hz, 1H), 5.79 (ddt, $J = 16.2, 10.2, 6.0$ Hz, 1H), 5.67 (ddt, $J = 17.1, 10.1, 4.9$ Hz, 1H), 5.21 – 5.02 (m, 4H), 4.03 (d, $J = 6.0$ Hz, 2H), 3.83 – 3.73 (m, 2H), 3.50 – 3.40 (m, 2H), 2.45 (t, $J = 7.1$ Hz, 2H), 2.28 – 2.20 (m, 2H). **$^{13}\text{C-NMR}$** (151 MHz, CDCl_3) δ 172.59, 136.27, 133.41, 132.81, 131.41, 130.94, 129.87, 128.86, 127.48, 127.36, 127.31, 126.62, 125.78, 125.07, 124.99, 124.81, 124.76, 124.71, 123.58, 117.17, 116.55, 49.15, 47.95, 32.89, 32.30, 27.02.

3. Flow protocol for the synthesis of cyclobutanones (**3a-r**) and scale up procedure

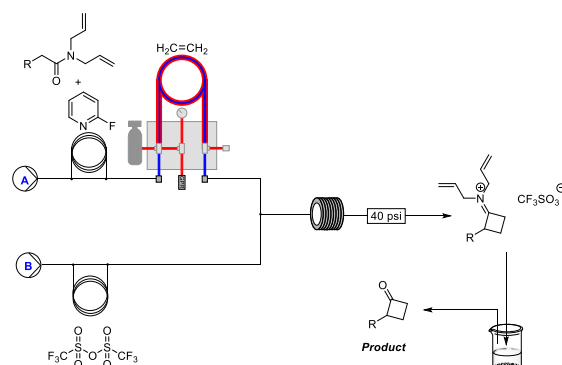

A solution of the amide (2.2 mmol, 0.20 M) and 2-fluoro-pyridine (2.64 mmol, 0.24 M) in anhydrous CH_2Cl_2 (loaded into a 10 mL injection loop, A) was pumped (flow rate 0.25 ml min^{-1}) through a tube-in-tube gas reactor pressurised with ethylene gas ($\Delta P = 10 \text{ bar}$) and combined at a T-piece with a solution of triflic anhydride (2.64 mmol, 0.24 M) in anhydrous CH_2Cl_2 (loaded into injection a 10 mL injection loop, B, and pumped at 0.25 ml min^{-1}) to react in a 10 mL perfluoroalkoxy (PFA) polymeric coil, heated at $60 \text{ }^\circ\text{C}$. The reactor output was directed through a 40 psi back pressure regulator, collected in a flask containing water and stirred overnight. The organic layer was recovered and the solvent was evaporated *in vacuo*. The crude mixture was purified by flash chromatography to give the cyclobutanone product **3a-r**.

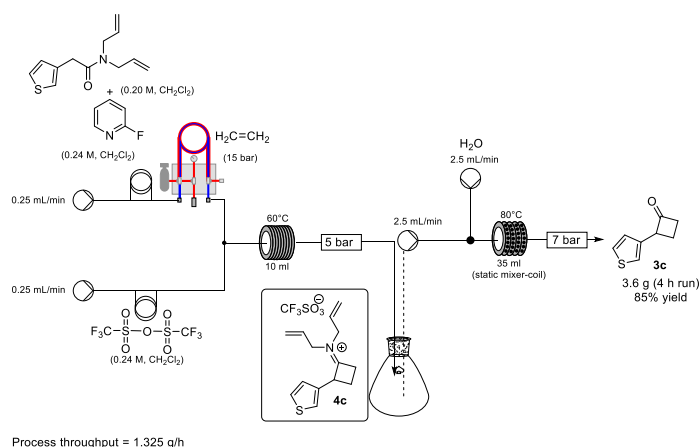

A solution of the amide **2c** (0.20 M) and 2-fluoro-pyridine (0.24 M) in anhydrous CH_2Cl_2 (Pump A) was pumped (flow rate 0.25 ml min^{-1}) through a tube-in-tube gas reactor pressurised with ethylene gas ($\Delta P = 10 \text{ bar}$) and combined at a T-piece with a solution of triflic anhydride (0.24 M) in anhydrous CH_2Cl_2 (loaded in a PFA coil 60 mL, Pump B) (flow rate 0.25 ml min^{-1}) to react in a 10 mL perfluoroalkoxy (PFA) polymeric coil, heated at $60 \text{ }^\circ\text{C}$. The reactor output was directed

through a 40 psi back pressure regulator and collected in a reservoir. The solution was then combined at a T-piece with a stream of distilled water (each channel pumped at 2.5 mL min⁻¹) and reacted at 80 °C in a static mixer coil (residence time of 7 min). The organic layer was recovered and the solvent was evaporated *in vacuo*. The crude mixture was purified by flash chromatography to give the cyclobutanone product **3s** (3.6 g, 85% yield).

3.1. Characterization data of cyclobutanones (3a-r)

2-(*p*-tolyl)cyclobutan-1-one (3a)

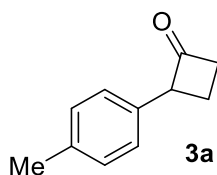

(SiO₂, CH₂Cl₂/ Hexane = 3:1). Yellowish oil (80 %). **FT-IR** (ν_{\max} , cm⁻¹) 1779. **¹H NMR** (600 MHz, CDCl₃) δ 7.17 (s, 4H), 4.56 – 4.48 (m, 1H), 3.28 – 3.19 (m, 1H), 3.09 – 3.00 (m, 1H), 2.60 – 2.50 (m, 1H), 2.36 (s, 3H), 2.27 – 2.19 (m, 1H). **¹³C NMR** (151 MHz, CDCl₃) δ 208.20, 136.61, 133.56, 129.33, 126.89, 64.33, 44.81, 21.08, 17.83. **HRMS** for C₁₁H₁₀ON, calculated 161.0966, found 161.0962.

2-(3-(trifluoromethyl)phenyl)cyclobutan-1-one (3b)

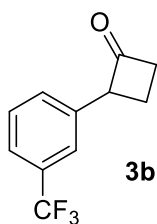

(SiO₂, CH₂Cl₂/ Hexane = 3:1). Yellowish oil (78 %). **FT-IR** (ν_{\max} , cm⁻¹) 1781. **¹H NMR** (600 MHz, CDCl₃) δ : 7.54 – 7.44 (m, 4H), 4.63 – 4.56 (m, 1H), 3.36 – 3.24 (m, 1H), 3.10-3.00 (m, 1H), 2.59 (ddd, *J* = 21.8, 10.7, 4.8 Hz, 1H), 2.31 – 2.23 (m, 1H). **¹³C NMR** (151 MHz, CDCl₃) δ : 206.40, 137.30, 130.93 (q, *J*= 32.2 Hz), 130.42, 130.41, 129.07, 123.80 (q, *J*= 3.7 Hz), 123.66 (q, *J*= 3.7 Hz), 63.84, 44.94, 17.49. **HRMS** for C₁₁H₉OF₃, calculated 214.0605, found 214.0600.

2-(thiophen-3-yl)cyclobutan-1-one (3c)

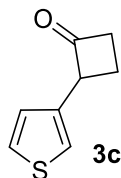

(SiO₂, CH₂Cl₂/ Hexane = 19:1). Yellow oil (83 %). **FT-IR** (ν_{\max} , cm⁻¹) 1775. **¹H-NMR** (600 MHz, CDCl₃) δ : 7.33 – 7.29 (m, 1H), 7.14 – 7.11 (m, 1H), 7.01 (dd, *J* = 5.0, 1.2 Hz, 1H), 4.55 (td, *J* = 8.2, 2.1 Hz, 1H), 3.26 – 3.17 (m, 1H), 3.01-3.09 (m, 1H), 2.54 (ddd, *J* = 21.5, 10.7, 5.0 Hz, 1H), 2.20 – 2.11 (m, 1H). **¹³C-NMR** (151 MHz, CDCl₃) δ : 207.40, 136.88, 126.56, 126.09, 120.72, 60.33, 44.98, 18.27. **HRMS** for C₈H₆OS, calculated 153.0374, found 153.0371.

2-(3,4-Dimethoxyphenyl)cyclobutan-1-one (3d)

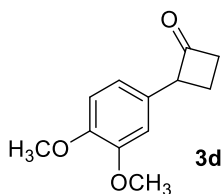

(SiO₂, CH₂Cl₂/ Hexane = 19:1). Orange amorphous solid, 91% yield. **FT-IR** (ν_{\max} , cm⁻¹) 1774. **¹H-NMR** (600 MHz, CDCl₃) δ : 6.82 – 6.71 (m, 3H), 4.47 – 4.40 (m, 1H), 3.85 (s, 3H), 3.82 (s, 3H), 3.22 – 3.11 (m, 1H), 3.01 – 2.92 (m, 1H), 2.48 (qd, J = 10.7, 4.9 Hz, 1H), 2.20 – 2.10 (m, 1H). **¹³C-NMR** (151 MHz, CDCl₃) δ : 208.19, 148.99, 148.00, 129.18, 118.94, 111.31, 110.38, 64.06, 55.89, 55.83, 44.64, 17.96. **HRMS** for C₁₂H₁₅O₃, calculated 207.1021, found 207.1015.

2-(benzo[d][1,3]dioxol-5-yl)cyclobutan-1-one (3e)

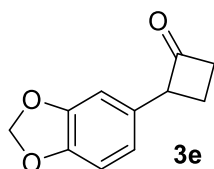

(SiO₂, CH₂Cl₂/ Hexane = 19:1). Red oil, 70 % yield. **FT-IR** (ν_{\max} , cm⁻¹) 1775. **¹H-NMR** (600 MHz, CDCl₃) δ : 6.80 – 6.72 (m, 2H), 6.72 – 6.66 (m, 1H), 5.93 (s, 2H), 4.48 – 4.41 (m, 1H), 3.26 – 3.15 (m, 1H), 3.04 – 2.96 (m, 1H), 2.51 (qd, J = 10.6, 4.9 Hz, 1H), 2.20 – 2.10 (m, 1H). **¹³C-NMR** (151 MHz, CDCl₃) δ : 207.96, 147.86, 146.52, 130.30, 120.08, 108.33, 107.57, 100.99, 64.19, 44.63, 18.10. **HRMS** for C₁₁H₁₁O₃, calculated 191.0708, found 191.0704.

2-(4-Methoxyphenyl)cyclobutan-1-one (3f)

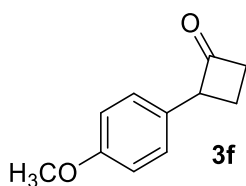

(SiO₂, Hexane/AcOEt = 19:1). Orange amorphous solid (75 %). **FT-IR** (ν_{\max} , cm⁻¹) 1777 (C=O ketone). **¹H-NMR** (600 MHz, CDCl₃), δ : 7.18 (d, J = 8.5 Hz, 2 H), 6.88 (d, J = 8.8 Hz, 2 H), 4.51-4.45 (m, 1 H), 3.80 (s, 3 H), 3.26- 3.17 (m, 1 H), 3.05- 2.98 (m, 1 H), 2.56- 2.48 (m, 1 H), 2.22- 2.14 (m, 1 H). **¹³C-NMR** (151 MHz, CDCl₃), δ ppm: 208.39, 158.59, 128.76, 128.08, 114.07, 63.93, 55.28, 44.72, 18.05. **HRMS** for C₁₁H₁₃O₂, calculated 177.0916, found 177.0917.

2,2'-(1,4-Phenylene)bis(cyclobutan-1-one) (3g)

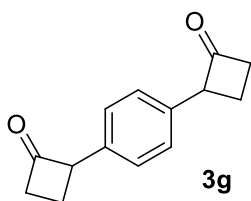

(SiO₂, CH₂Cl₂/ Hexane = 70:30). Yellowish solid, 78 % yield. **FT-IR** (ν_{\max} , cm⁻¹) 1765. **¹H NMR** (600 MHz, CDCl₃) δ 7.23 (s, 4H), 4.58 – 4.49 (m, 2H), 3.28 – 3.19 (m, 2H), 3.09 – 2.99 (m, 2H), 2.54 (qd, J = 10.7, 4.9 Hz, 2H), 2.28 – 2.16 (m, 2H). **¹³C NMR** (151 MHz, CDCl₃) δ 207.70, 135.23, 127.25, 64.22, 44.86, 17.72. **HRMS** for C₁₄H₁₅O₂, calculated 215.1072, found 215.1067.

2-(Benzofuran-3-yl)cyclobutan-1-one (3h)

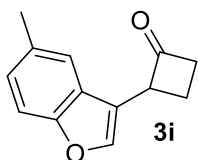

(SiO₂, CH₂Cl₂/ Hexane = 3:1). Yellowish oil, 65 % yield. **FT-IR** (ν_{\max} , cm⁻¹) 1779. **¹H-NMR** (600 MHz, CDCl₃) δ 7.55 (d, J = 1.0 Hz, 1H), 7.36 (d, J = 8.4 Hz, 1H), 7.32 (s, 1H), 7.13 (dd, J = 8.4, 1.1 Hz, 1H), 4.68 – 4.59 (m, 1H), 3.39 – 3.29 (m, 1H), 3.21 – 3.15 (m, 1H), 2.63 (qd, J = 10.7, 5.0 Hz, 1H), 2.26 – 2.18 (m, 1H). **¹³C-NMR** (151 MHz, CDCl₃) δ 206.85, 153.87, 141.27, 132.14, 126.73, 125.92, 119.63, 115.90, 111.14, 55.24, 45.55, 21.38, 17.36.

2-(2-Chlorophenyl)cyclobutan-1-one (3i)

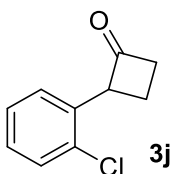

(SiO₂, CH₂Cl₂/ Hexane = 19:1). Orange oil, 51 % yield. **FT-IR** (ν_{\max} , cm⁻¹) 1779. **¹H-NMR** (600 MHz, CDCl₃) δ : 7.57 – 7.44 (m, 4H), 4.65 – 4.58 (m, 1H), 3.35 – 3.27 (m, 1H), 3.13- 3.05 (m, 1H), 2.62 (qd, J = 10.7, 4.8 Hz, 1H), 2.33 – 2.25 (m, 1H). **¹³C-NMR** (151 MHz, CDCl₃) δ : 206.40, 137.25, 130.40, 129.07, 123.85, 123.82, 123.67, 123.65, 63.85, 44.98, 17.49. **HRMS** for C₁₀H₁₀OCl, calculated 181.0420, found 181.0416.

2-(4-Cyanophenyl)cyclobutan-1-one (3j)

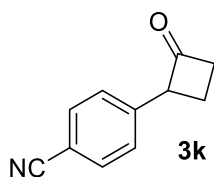

(SiO₂, CH₂Cl₂/ Hexane = 19:1). Yellow oil, 60 % yield. **FT-IR** (ν_{\max} , cm⁻¹) 1778. **¹H-NMR** (600 MHz, CDCl₃) δ = 7.62 (d, J =8.2 Hz, 2 H), 7.38 (d, J =8.0 Hz, 2 H), 4.61 (m, 1 H), 3.34 – 3.25 (m, 1 H), 3.11 – 3.02 (m, 1 H), 2.60 (qd, J =10.7, 4.8 Hz, 1 H), 2.31 – 2.22 (m, 1 H). **¹³C-NMR** (151 MHz, CDCl₃) δ = 205.70, 141.52, 132.38, 127.70, 118.73, 110.76, 64.00, 45.08, 17.21. **HRMS** for C₁₁H₁₀ON, calculated 172.0762, found 172.0757.

2-(4-Nitrophenyl)cyclobutan-1-one (3k)

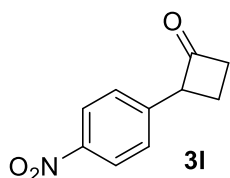

(SiO₂, CH₂Cl₂/ Hexane = 3:1). Red amorphous solid, 60 % yield. **FT-IR** (ν_{\max} , cm⁻¹) 1780. **¹H-NMR** (600 MHz, CDCl₃) δ : 8.15 (d, J = 8.2 Hz, 2 H), 7.42 (d, J = 8.2 Hz, 2 H), 4.66 (m, 1 H), 3.35-3.27 (m, 1 H), 3.12- 3.03 (m, 1 H), 2.67-2.59 (m, 1 H), 2.34-2.25 (m, 1 H). **¹³C-NMR** (151 MHz, CDCl₃) δ : 205.46, 146.80, 143.59, 127.75, 123.76, 63.81, 45.13, 17.28. **HRMS** for C₁₀H₉O₃N, calculated 191.0582, found 191.0579.

Ethyl 8-(2-oxocyclobutyl)octanoate (l)

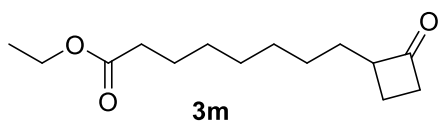

(SiO₂, CH₂Cl₂/ Hexane = 3:1). Yellowish oil, 52 % yield. **FT-IR** (ν_{\max} , cm⁻¹) 1777, 1740. **¹H-NMR** (600 MHz, CDCl₃) δ 4.14 (q, J = 7.1 Hz, 2H), 3.32 – 3.25 (m, 1H), 3.07 – 2.89 (m, 2H), 2.30 (t, J = 7.5 Hz, 2H), 2.19 (ddd, J = 21.0, 10.4, 5.2 Hz, 1H), 1.74 – 1.59 (m, 4H), 1.53 – 1.45 (m, 1H), 1.40 – 1.26 (m, 11H). **¹³C-NMR** (151 MHz, CDCl₃) δ 77.21 (s), 77.00 (s), 76.79 (s), 60.58 (s), 60.16 (s), 44.41 (s), 29.53 (s), 29.24 (s), 29.05 (d, J = 2.7 Hz), 26.97 (s), 24.93 (s), 16.90 (s), 14.26 (s).

2-(9-Bromononyl)cyclobutan-1-one (3m)

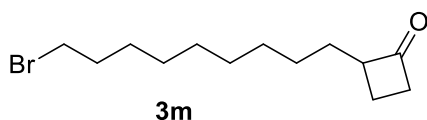

(SiO₂, CH₂Cl₂/ Hexane = 3:1). White amorphous solid, 68 % yield. **FT-IR** (ν_{\max} , cm⁻¹) 1779. **¹H NMR** (600 MHz, CDCl₃) δ 3.42 (t, J = 6.9 Hz, 2H), 3.07 – 2.90 (m, 2H), 2.19 (ddd, J = 21.1, 10.4, 5.2 Hz, 1H), 1.90 – 1.84 (m, 2H), 1.73 – 1.62 (m, 2H), 1.53 – 1.26 (m, 14H). **¹³C NMR** (151 MHz, CDCl₃) δ 212.44, 60.59, 44.39, 29.54, 29.38, 29.32, 29.30, 28.71, 28.13, 27.00, 16.

2-Hexylcyclobutan-1-one (3n)

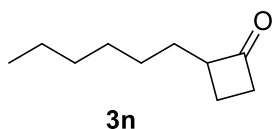

(SiO₂, CH₂Cl₂: Hexane = 19: 1). Yellowish oil, > 95 % yield (with internal standard). **FT-IR** (ν_{\max} , cm⁻¹) 1776. **¹H-NMR** (600 MHz, CDCl₃) δ 3.29 – 3.22 (m, 1H), 3.04 – 2.95 (m, 1H), 2.93 – 2.85 (m, 1H), 2.15 (ddd, J = 21.1, 10.4, 5.2 Hz, 1H), 1.71 – 1.58 (m, 2H), 1.51 – 1.42 (m, 1H), 1.39 – 1.16 (m, 8H), 0.85 (t, J = 7.0 Hz, 3H). **¹³C-NMR** (151 MHz, CDCl₃) δ 212.65, 60.56, 44.35, 31.64, 29.53, 29.11, 26.97, 22.58, 16.86, 14.06. **HRMS** for C₁₀H₁₉O, calculated 155.1436, found 155.1435.

Spiro[3.5]nonan-1-one (3o)

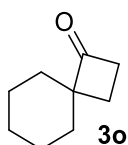

(SiO₂, CH₂Cl₂: Hexane = 9: 1). Colorless oil (65 % evaluated with trimethoxybenzene as internal standard). **FT-IR** (ν_{\max} , cm⁻¹) 1764. **¹H-NMR** (600 MHz, CDCl₃) δ : 2.95 (t, J = 8.2 Hz, 2H), 1.81 (t, J = 8.4 Hz, 2H), 1.71 – 1.32 (m, 10H). **¹³C-NMR** (151 MHz, CDCl₃) δ 216.07, 65.70, 41.21, 32.04, 25.43, 24.09, 22.47.

2-(Prop-2-yn-1-yl)cyclobutan-1-one (3p)

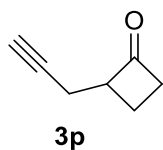

(SiO₂, CH₂Cl₂: Hexane = 19:1). Colorless oil, 47% yield (with internal standard). **FT-IR** (ν_{\max} , cm⁻¹) 3300, 1778. **¹H-NMR** (600 MHz, CDCl₃) δ 3.53 – 3.45 (m, 1H), 3.18 – 3.06 (m, 1H), 3.04 – 2.94 (m, 1H), 2.54 – 2.47 (m, 2H), 2.31 – 2.23 (m, 1H), 2.04 – 1.91 (m, 2H). **¹³C-NMR** (151 MHz, CDCl₃) δ 209.14, 80.39, 69.72, 57.71, 45.17, 18.13, 15.84.

2-Benzylcyclobutan-1-one (3q)

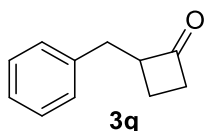

(SiO₂, CH₂Cl₂/ Hexane = 95:5). Yellowish oil (92 %). **IR** (ν_{\max} , cm⁻¹) 1772 (C=O ketone). **¹H NMR** (600 MHz, CDCl₃) δ 7.38 – 7.29 (m, 2H), 7.26 – 7.19 (m, 3H), 3.70 – 3.55 (m, 1H), 3.13 – 2.97 (m, 2H), 2.96 – 2.74 (m, 2H), 2.17 (ddd, J = 21.2, 10.5, 5.1 Hz, 1H), 1.85 – 1.69 (m, 1H). **¹³C NMR** (151 MHz, CDCl₃) δ 210.83, 138.91, 128.77, 128.52, 126.34, 61.20, 44.49, 35.20, 16.64. **HRMS** for C₁₁H₁₃O, calculated 161.0966, found 161.0967.

2-(2-(Pyren-2-yl)ethyl)cyclobutan-1-one (3r)

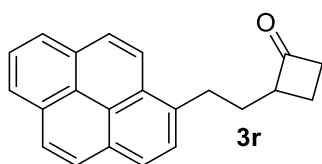

(SiO₂, CH₂Cl₂/ Hexane = 70:30). Yellow oil (61 %). **IR** (ν_{\max} , cm⁻¹) 1770 (C=O ketone). **¹H NMR** (600 MHz, CDCl₃) δ 8.28 (d, J = 9.2 Hz, 1H), 8.21 – 8.17 (m, 2H), 8.12 (dd, J = 8.5, 5.9 Hz, 2H), 8.02 (t, J = 7.6 Hz, 3H), 7.86 (d, J = 7.8 Hz, 1H), 3.56 – 3.44 (m, 1H), 3.42 – 3.32 (m, 2H), 3.09-3.0 (m, 1 H), 3.0-2.92 (m, 1 H), 2.31 – 2.23 (m, 1H), 2.14 (ddd, J = 21.2, 10.5, 5.2 Hz, 1H), 2.09 – 2.01 (m, 1H), 1.69 – 1.62 (m, 1H). **¹³C NMR** (151 MHz, CDCl₃) δ 211.97, 135.67, 131.44, 130.92, 129.99, 128.72, 127.51, 127.44, 127.33, 126.76, 125.89, 125.10, 125.01, 124.97, 124.86, 124.82, 123.27, 59.93, 44.62, 31.67, 30.82, 17.06. **HRMS** for C₂₂H₁₉O, calculated 299.1436, found 299.1428.

^1H - and ^{13}C -NMR data

2-(*p*-Tolyl)cyclobutan-1-one (3a)

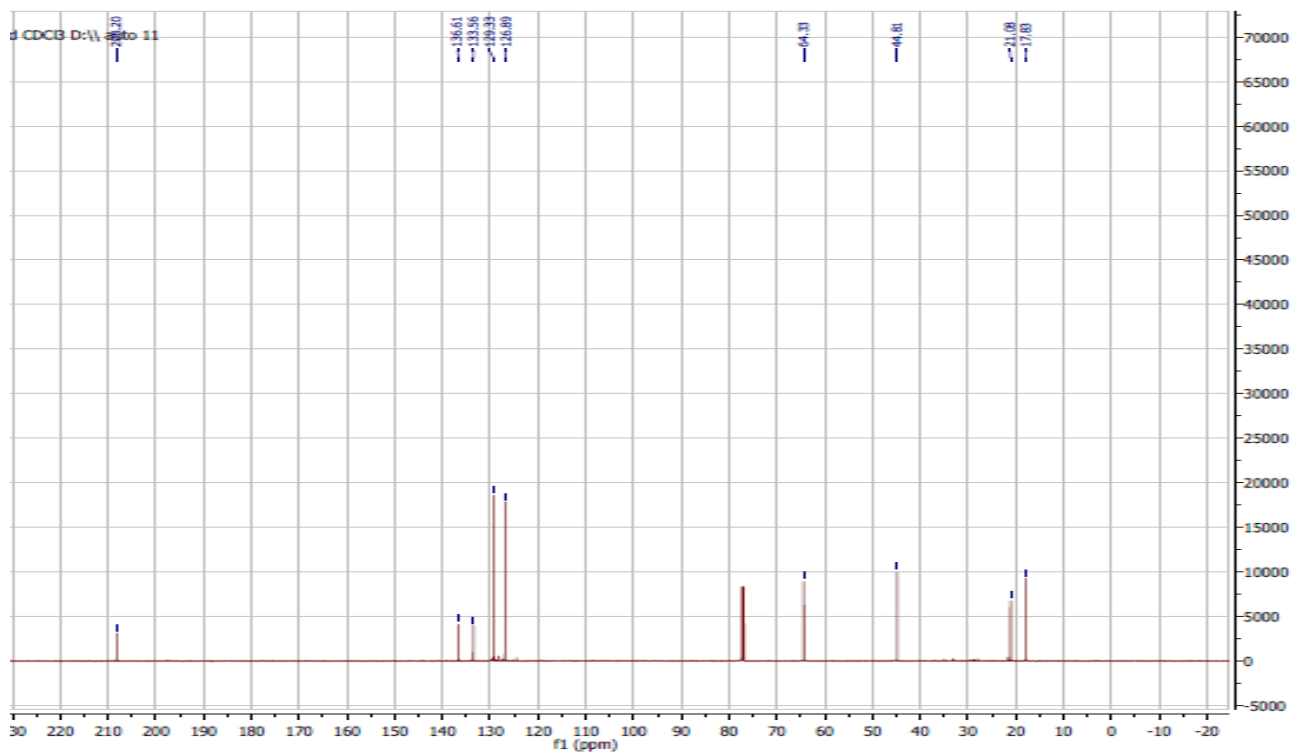
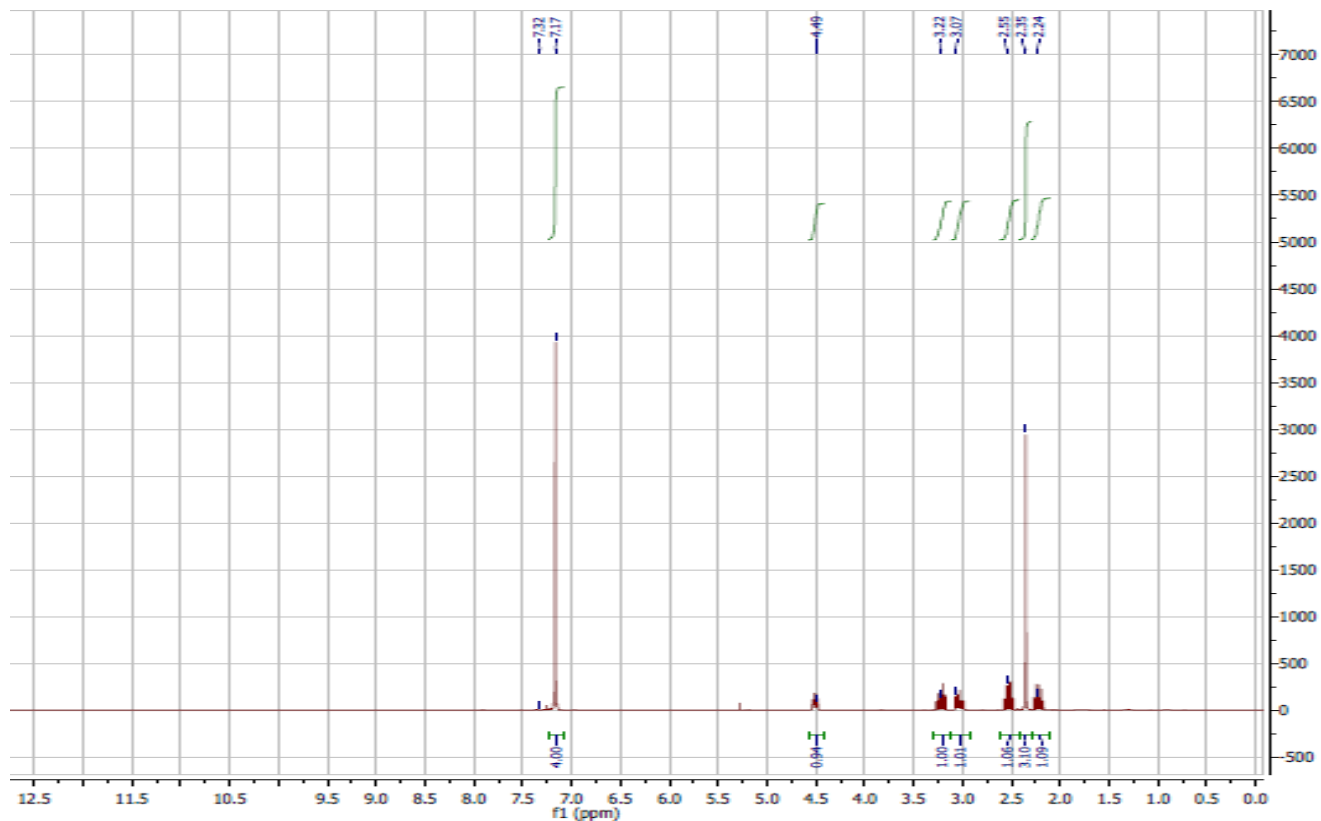

2-(3-(Trifluoromethyl)phenyl)cyclobutan-1-one (3b)

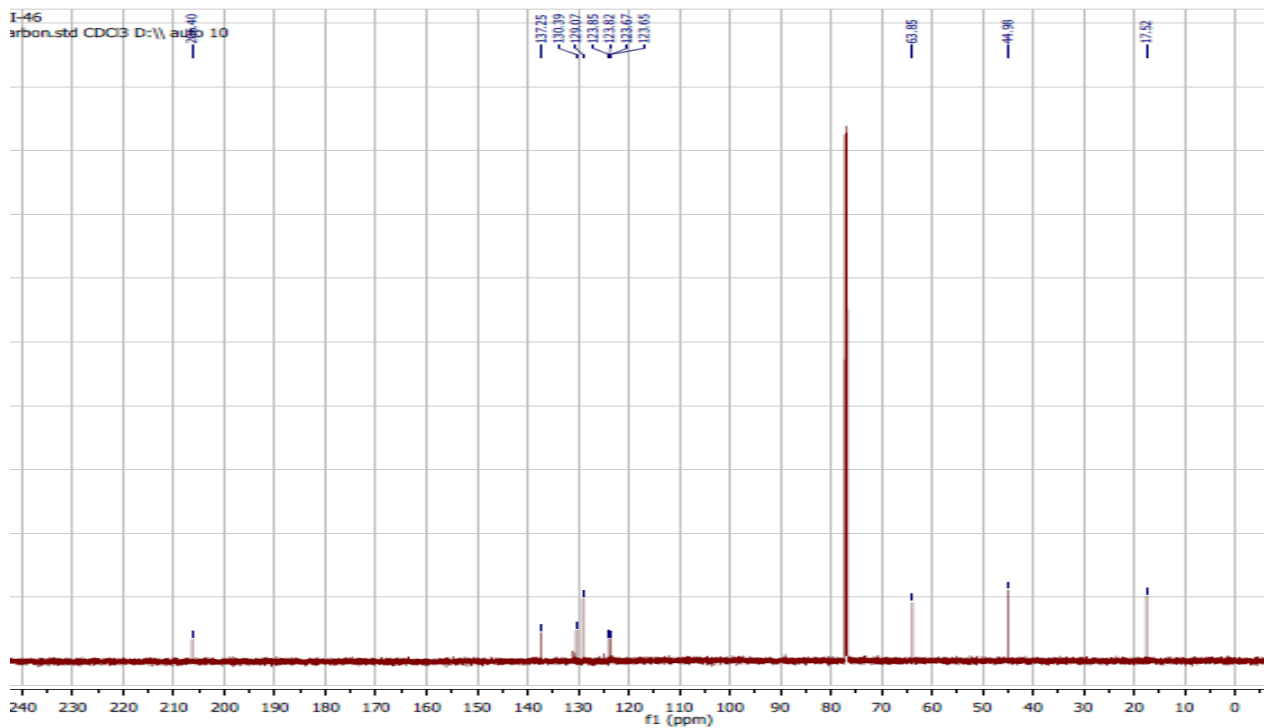
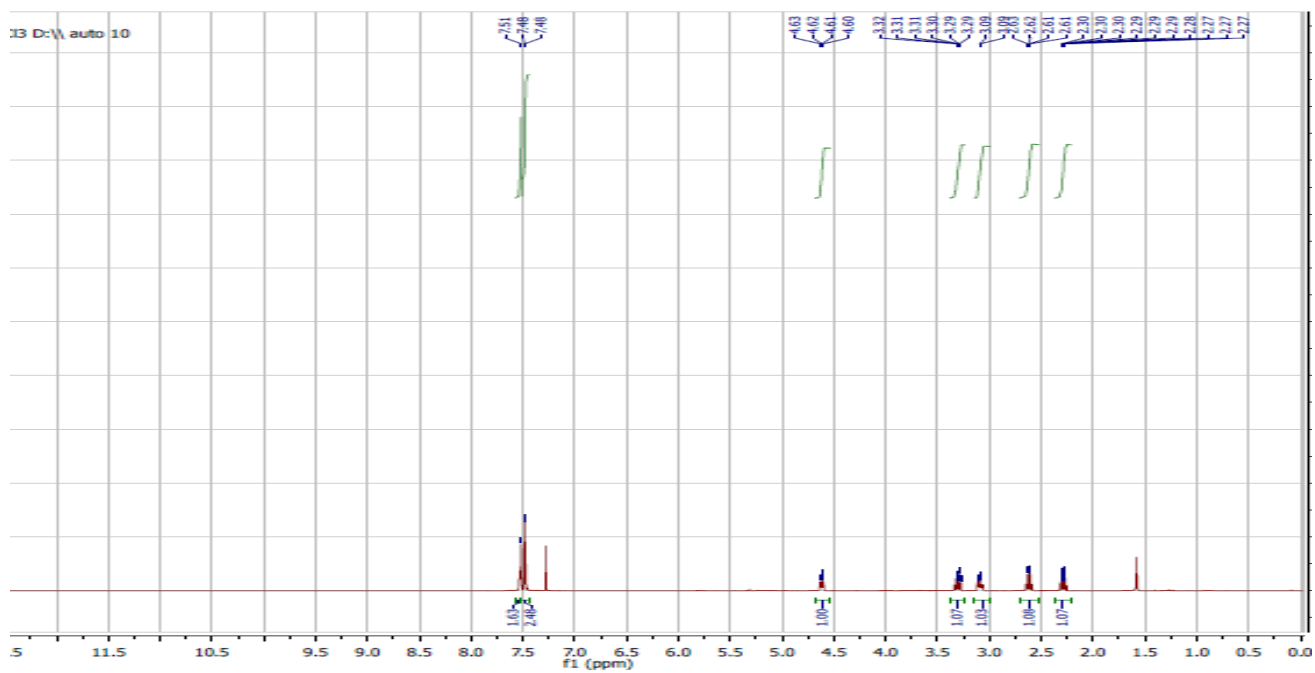

2-(Thiophen-3-yl)cyclobutan-1-one (3c)

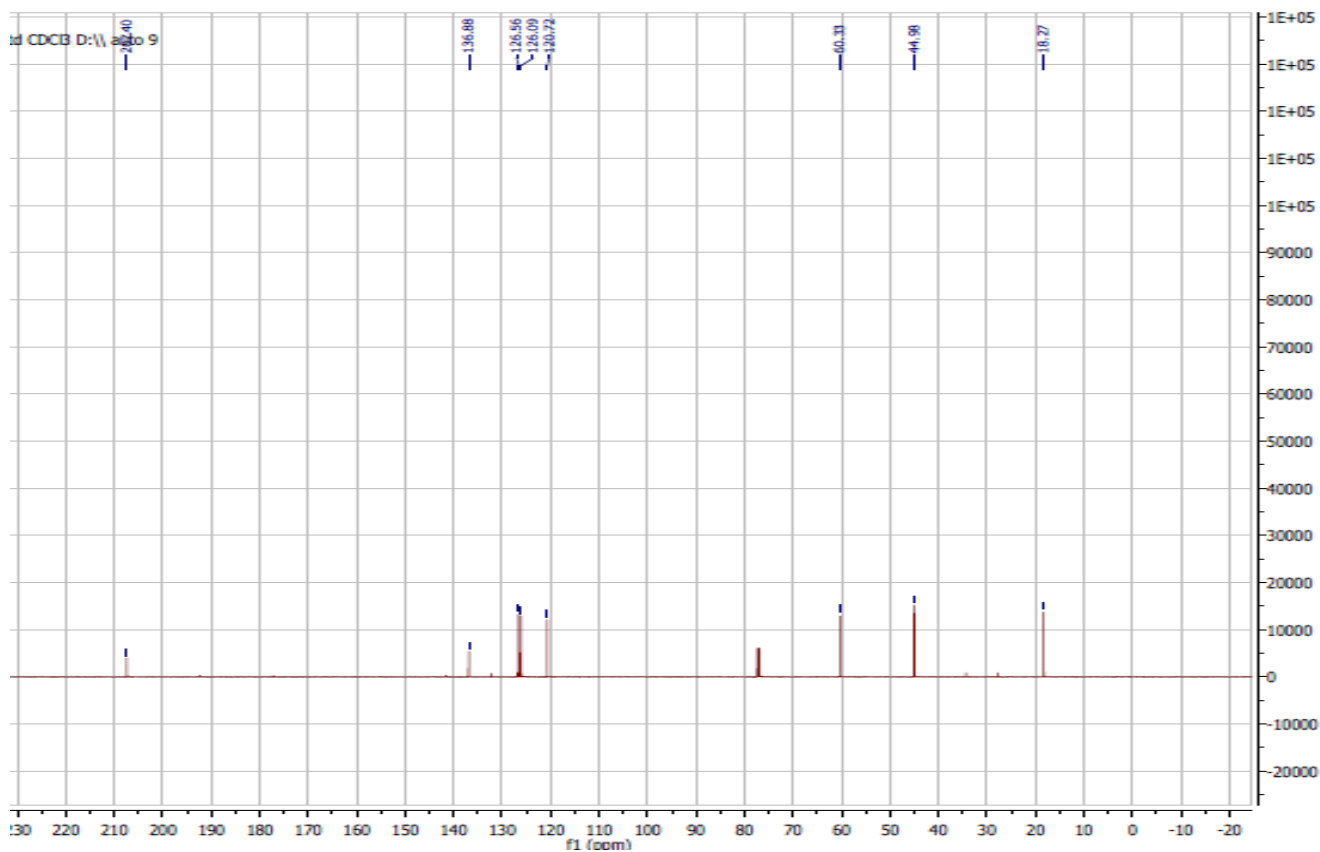
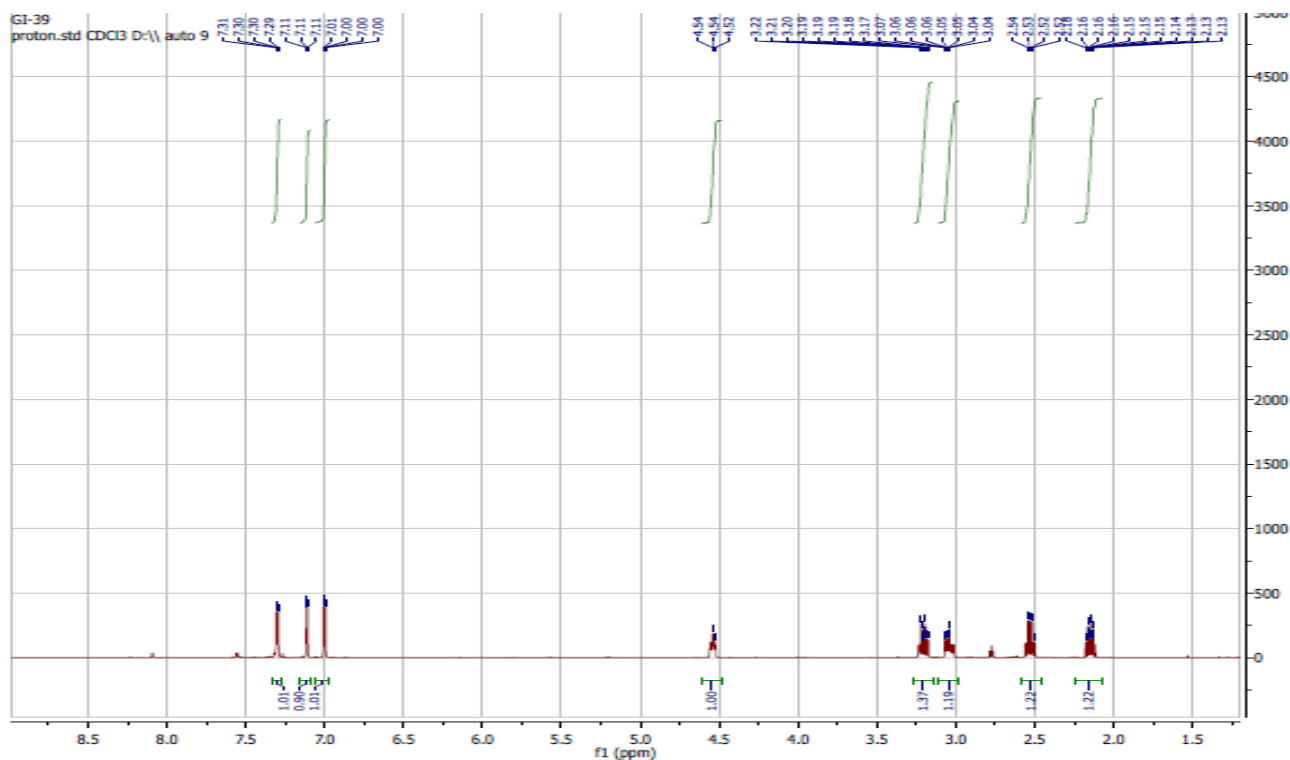

2-(3,4-Dimethoxyphenyl)cyclobutan-1-one (3d)

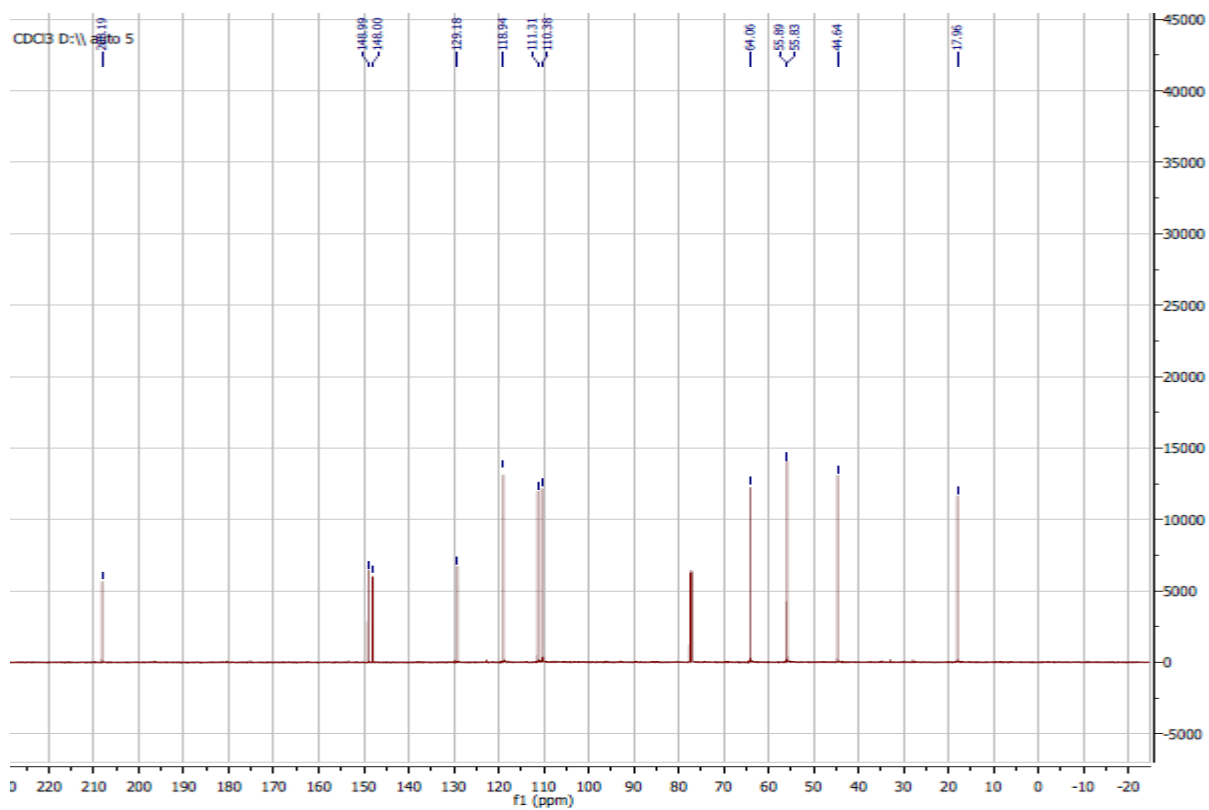
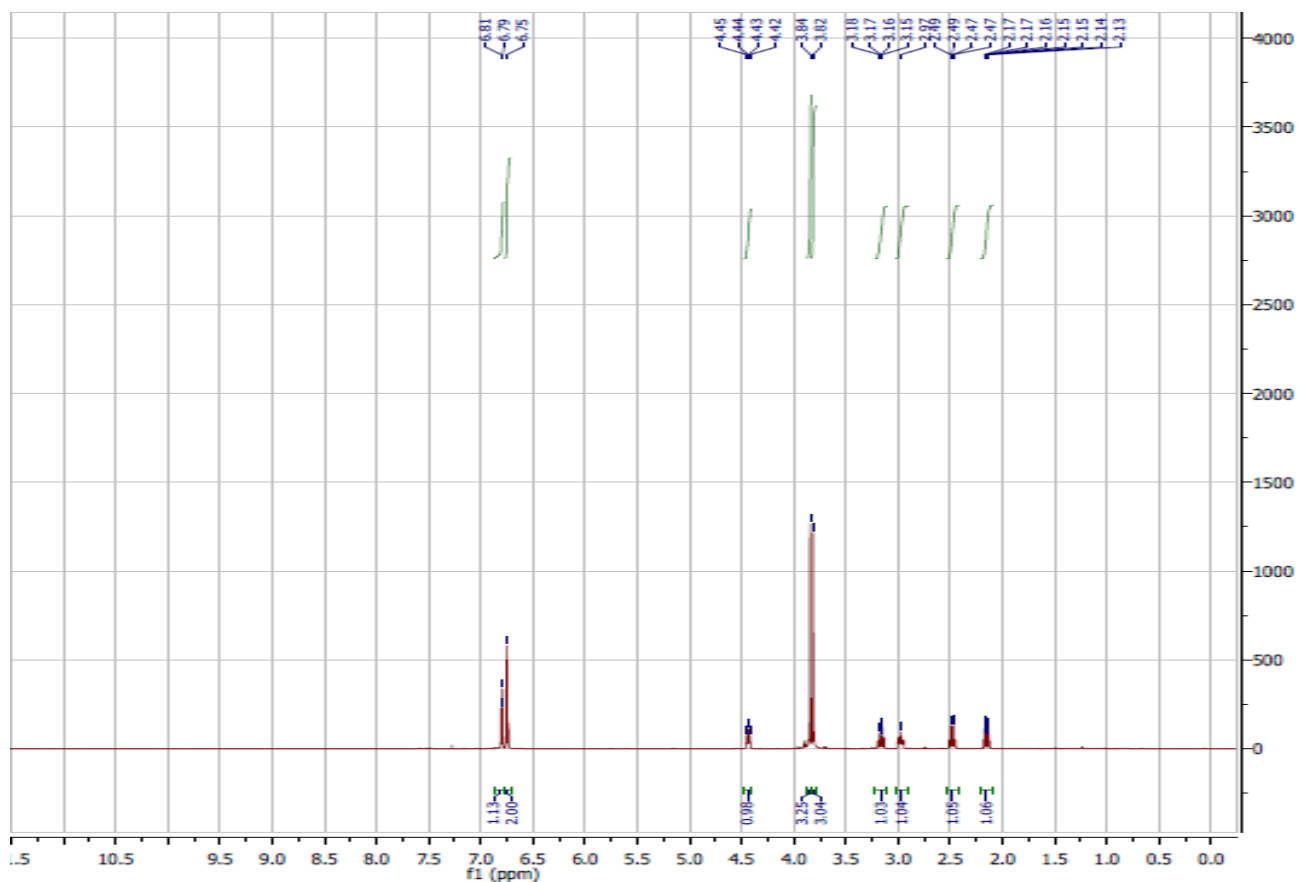

2-(Benzo[d][1,3]dioxol-5-yl)cyclobutan-1-one (3e)

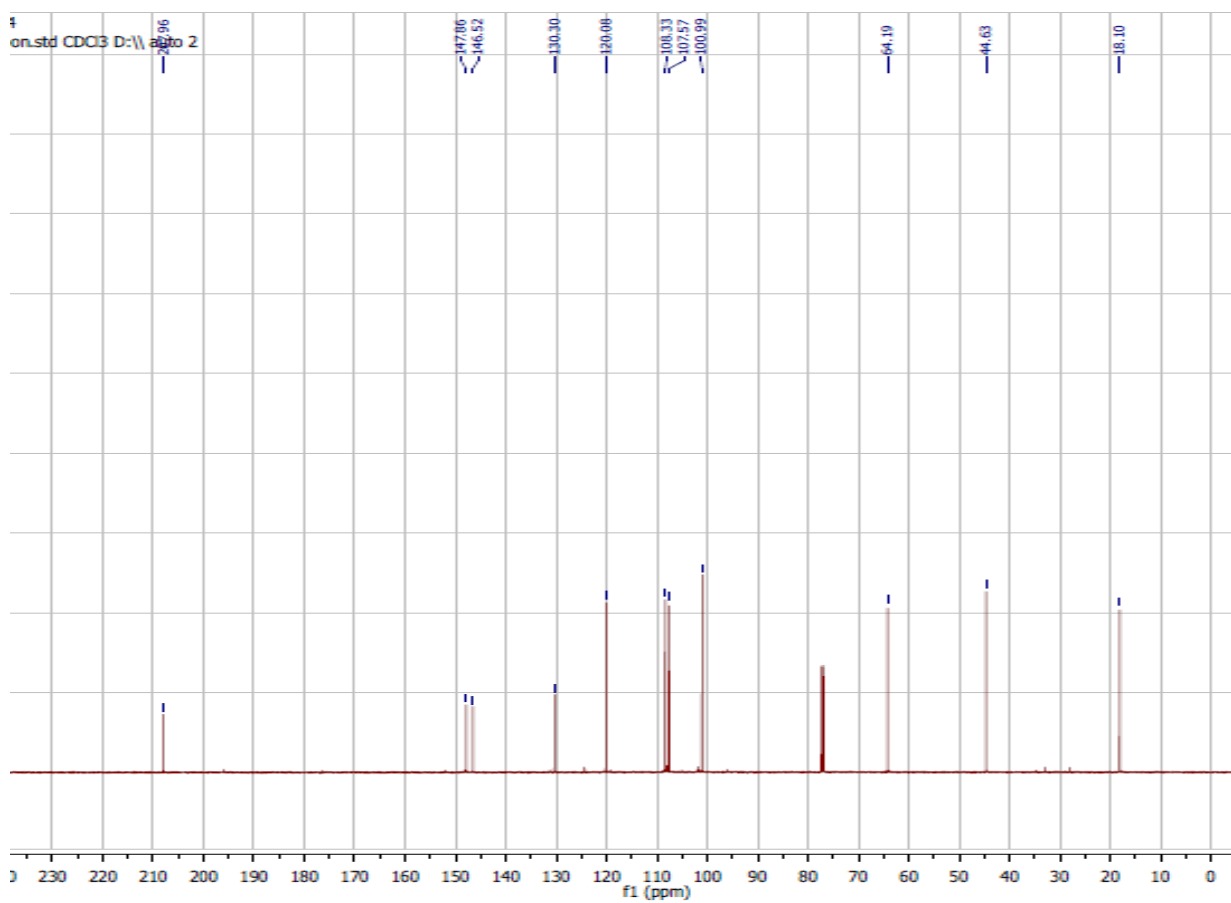
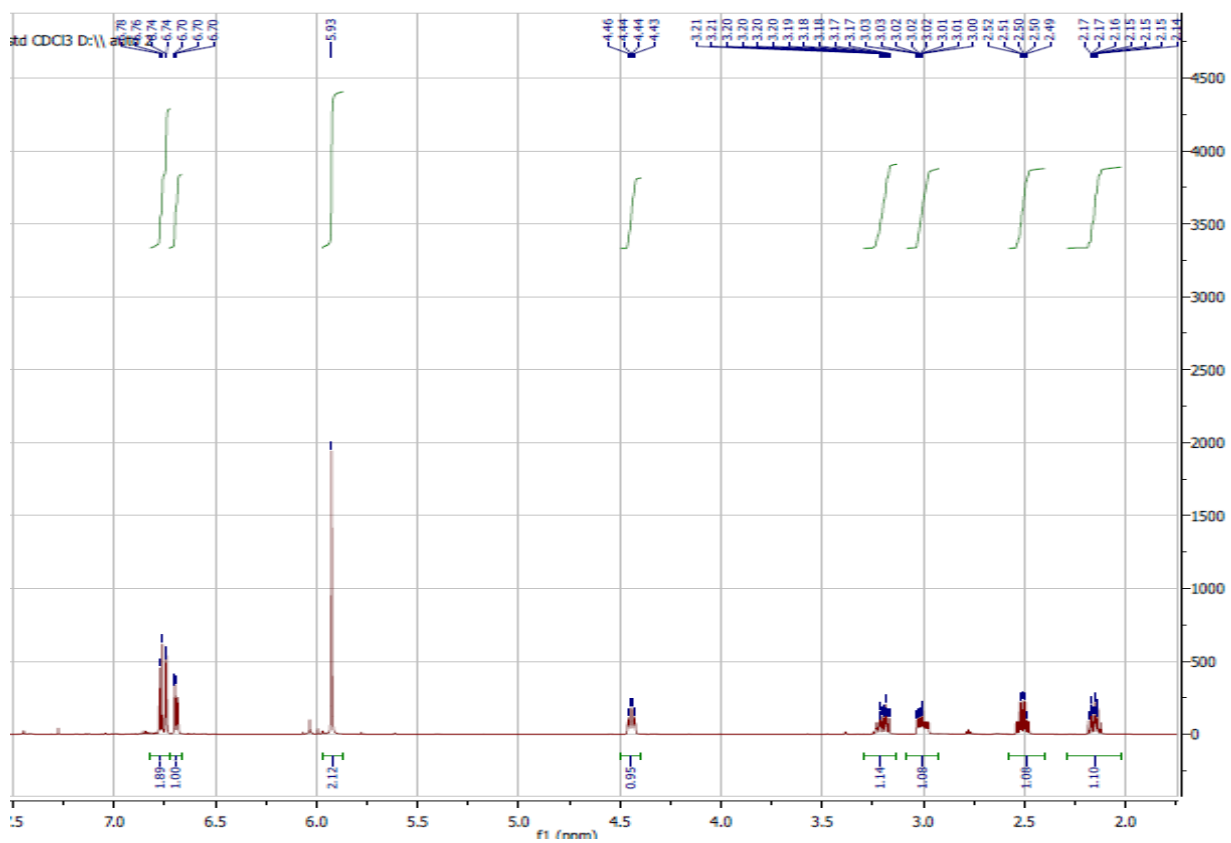

2-(4-Methoxyphenyl)cyclobutan-1-one (3f)

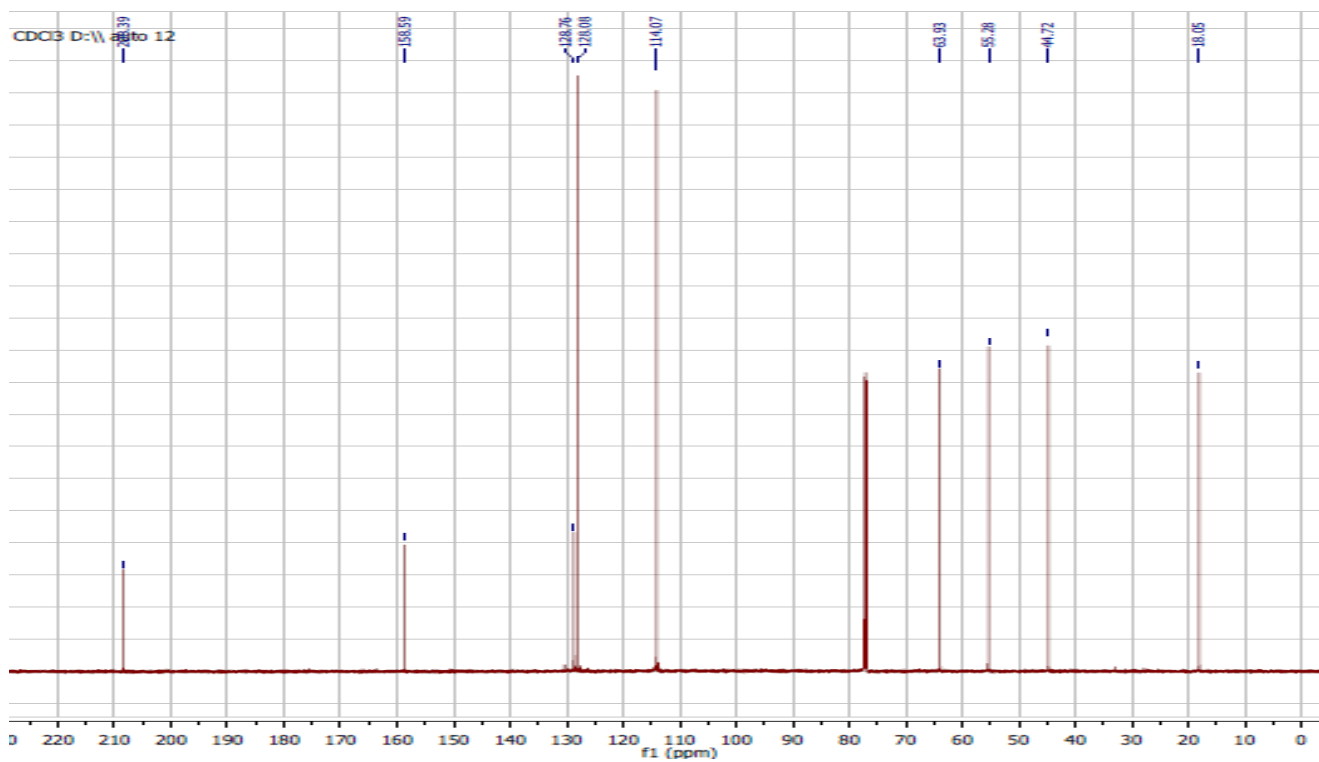
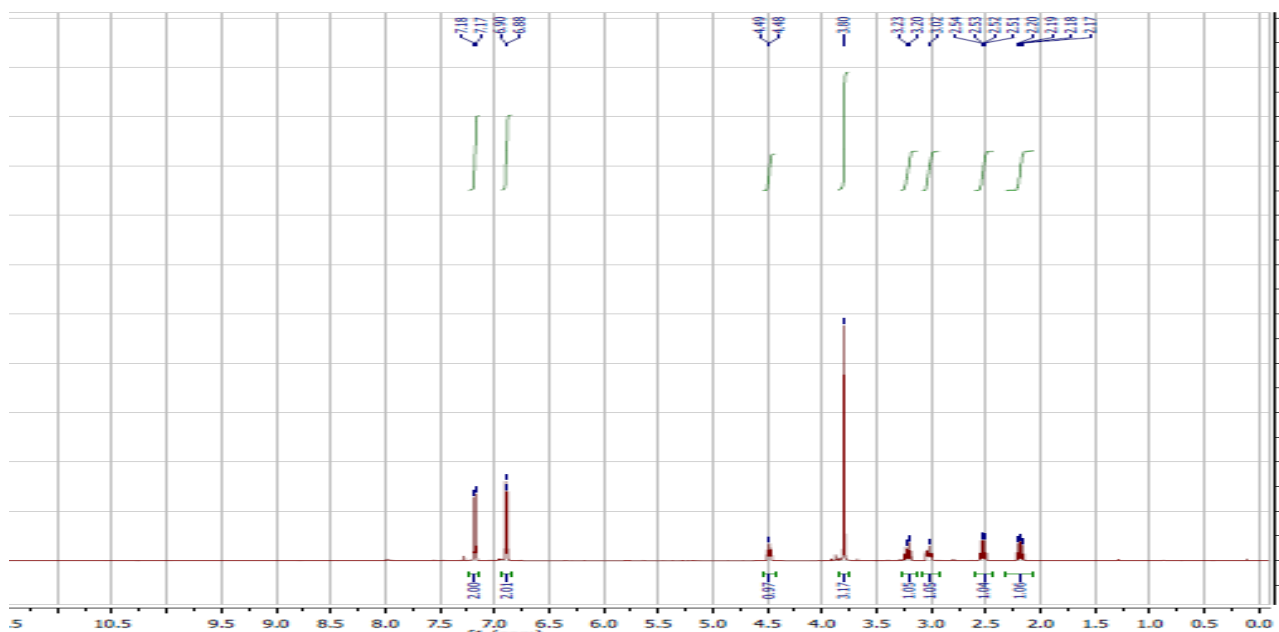

2,2'-(1,4-Phenylene)bis(cyclobutan-1-one) (3g)

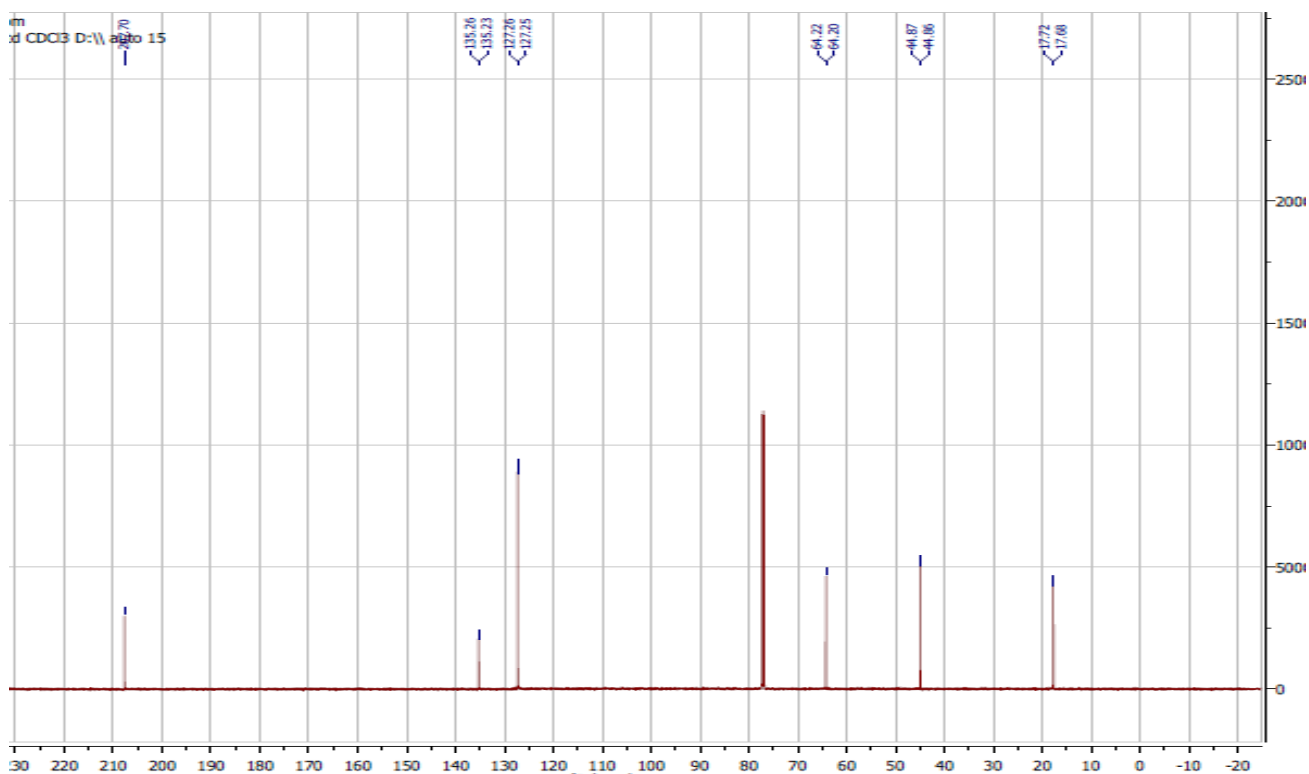
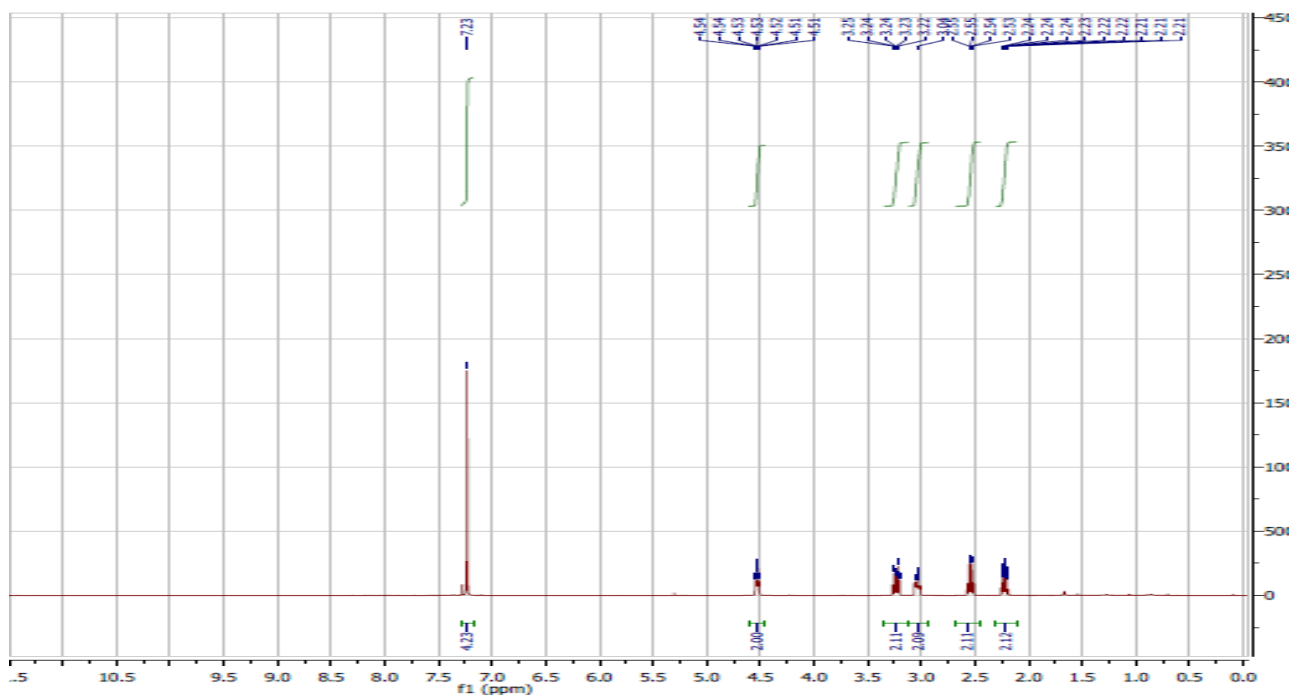

2-(5-Methyl-benzofuran-3-yl)cyclobutan-1-one (3h)

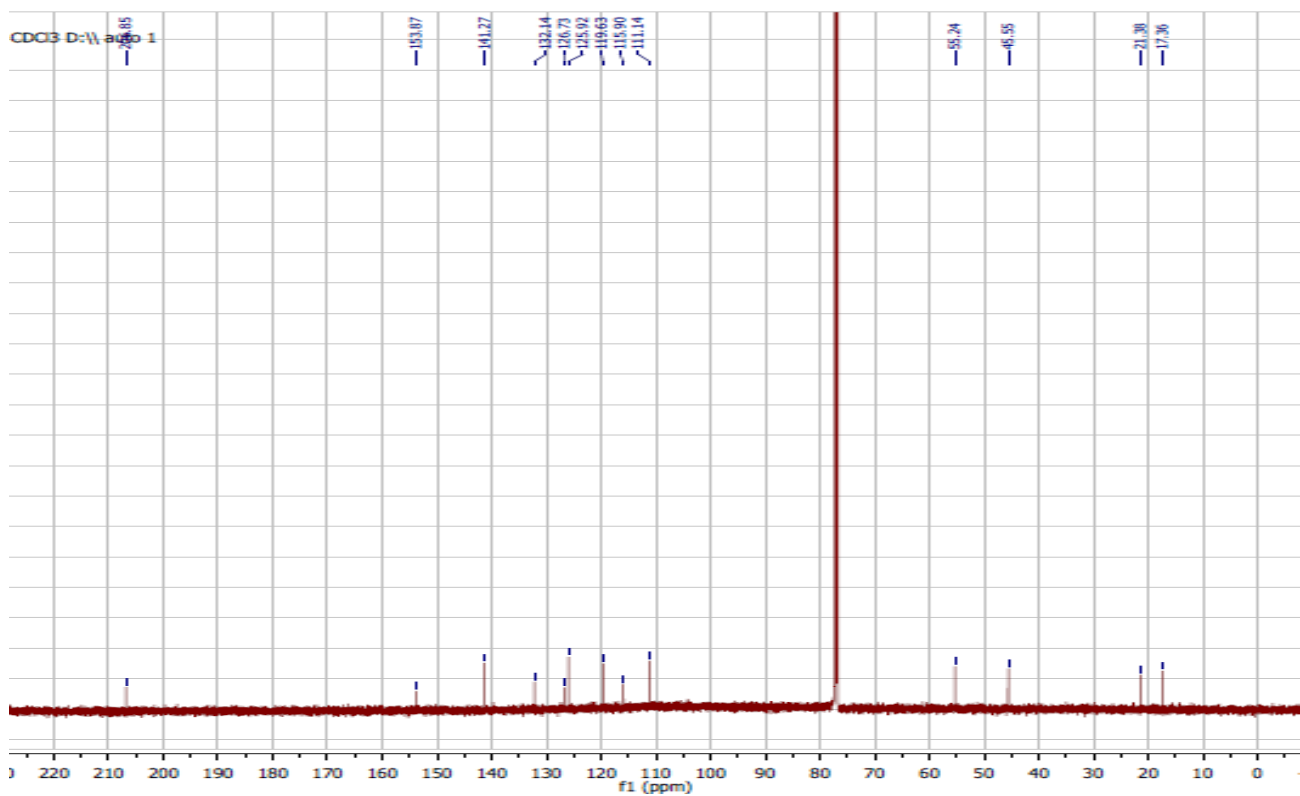
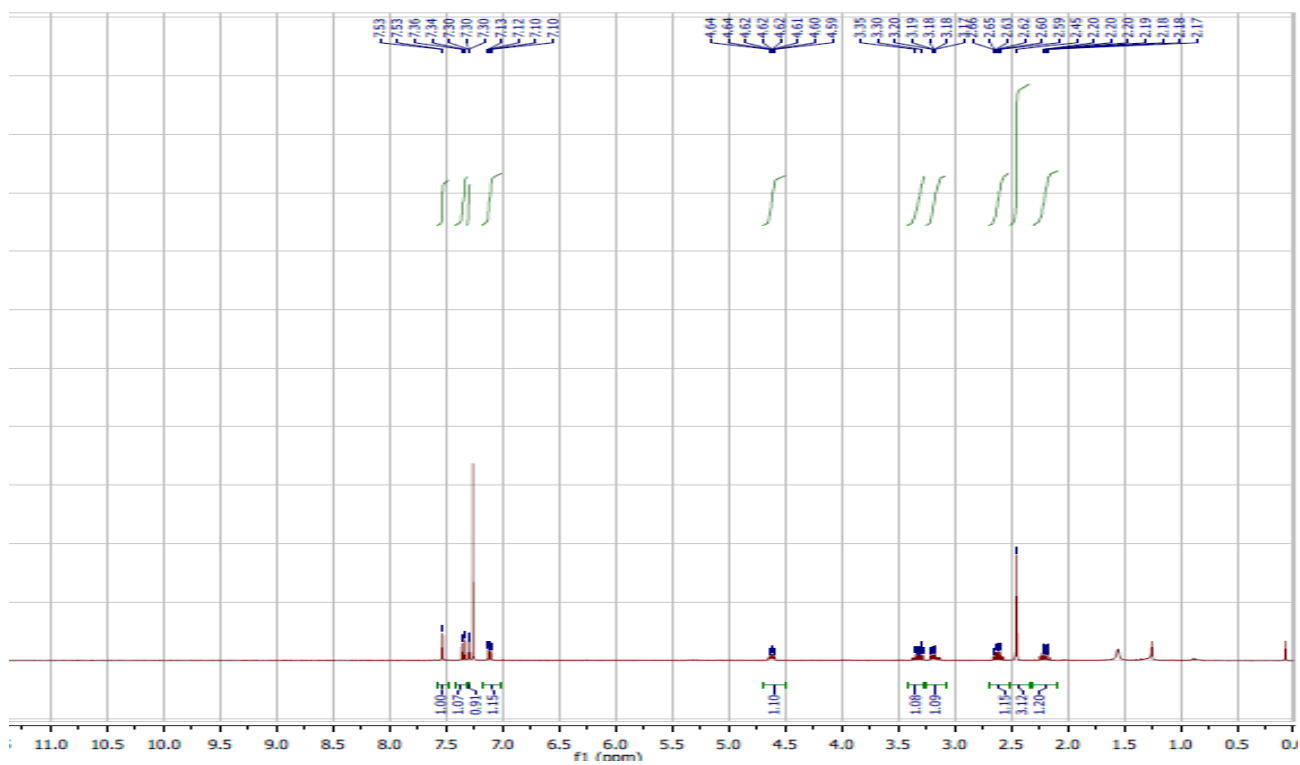

2-(2-Chlorophenyl)cyclobutan-1-one (3i)

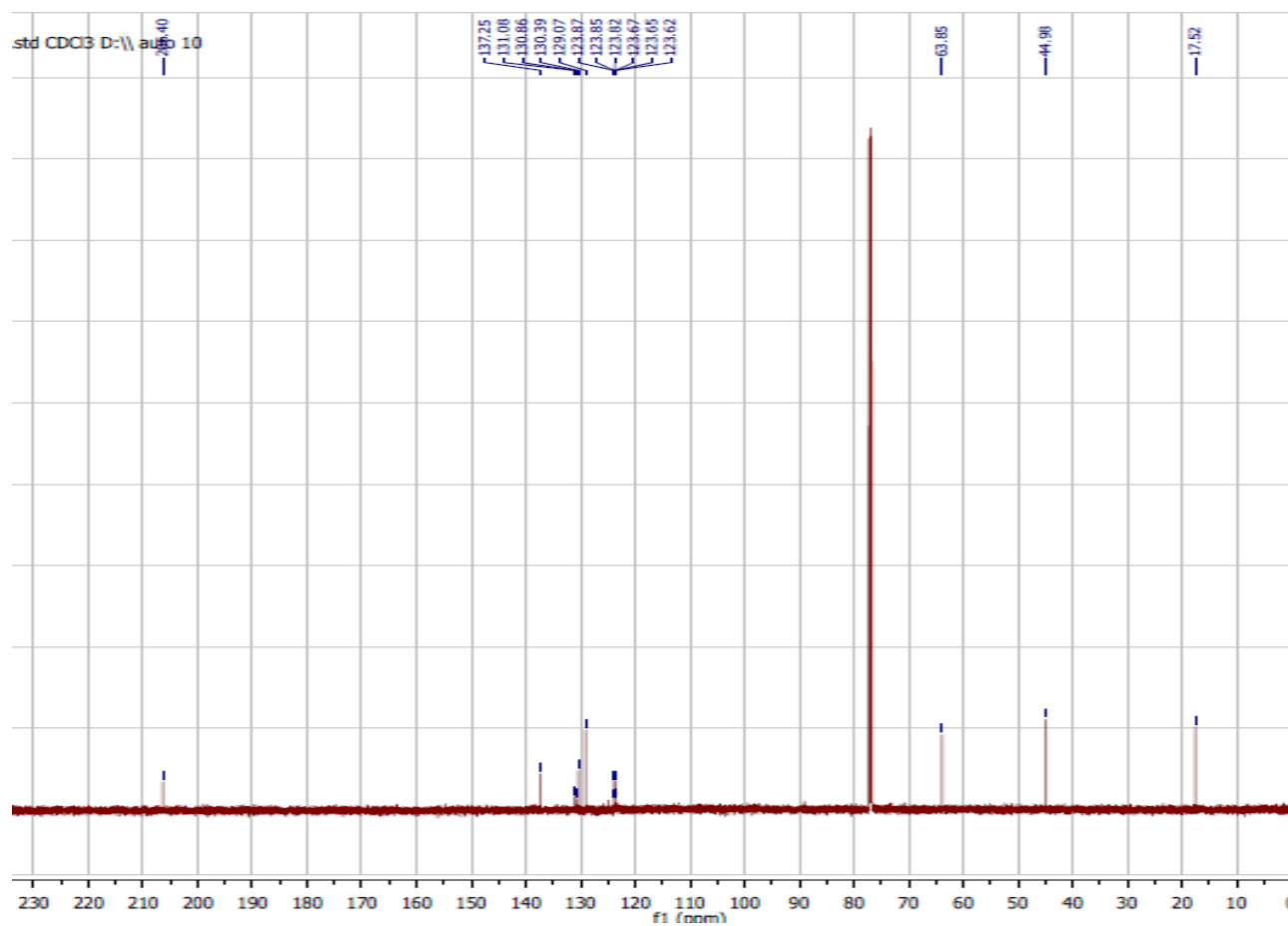
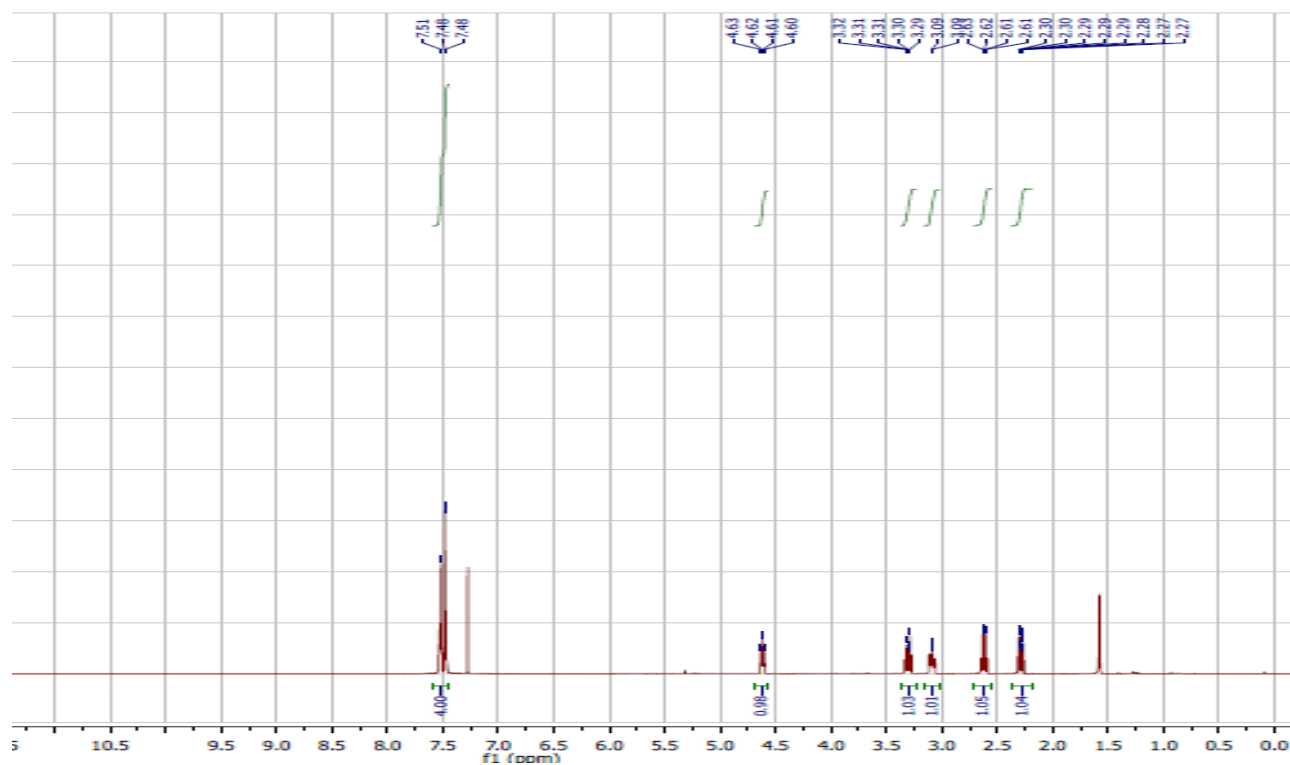

(4-Cyanophenyl)cyclobutan-1-one (3j)

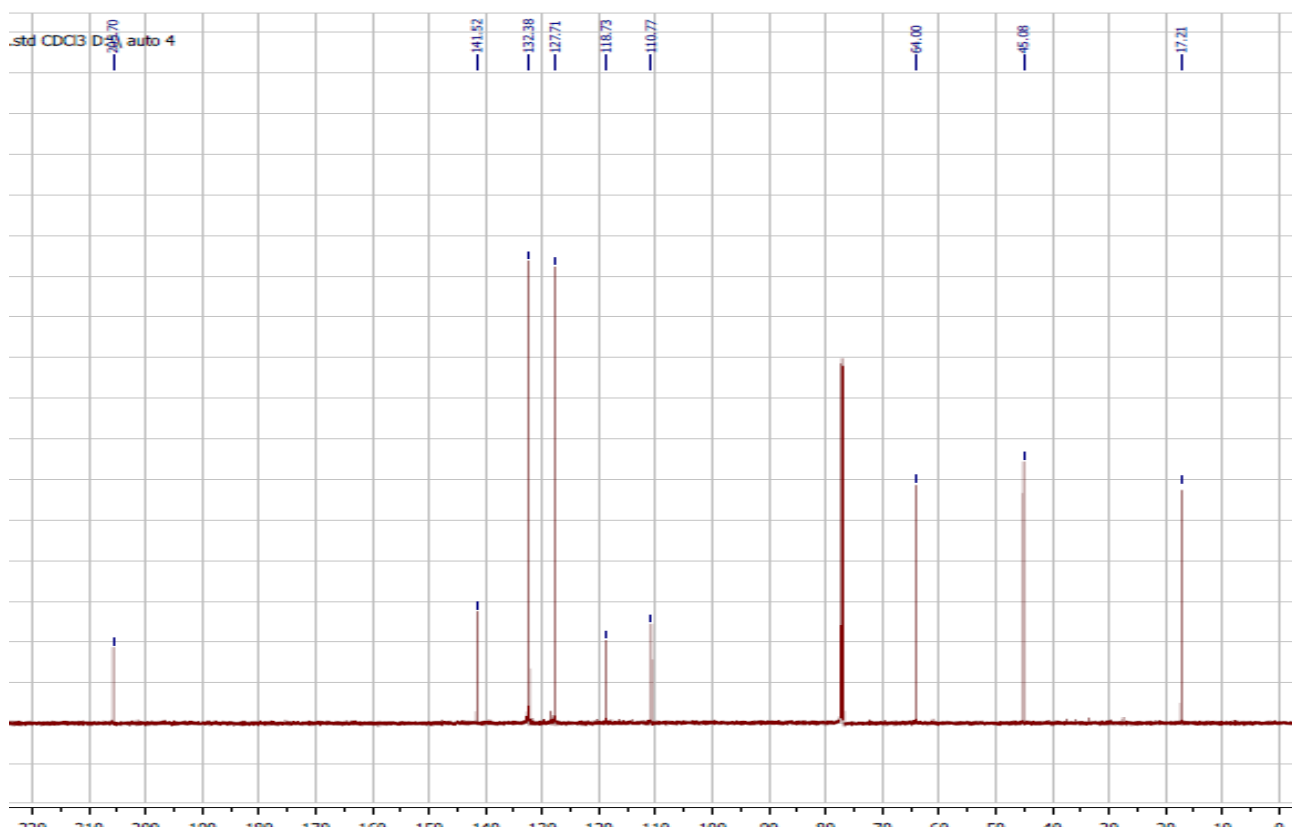
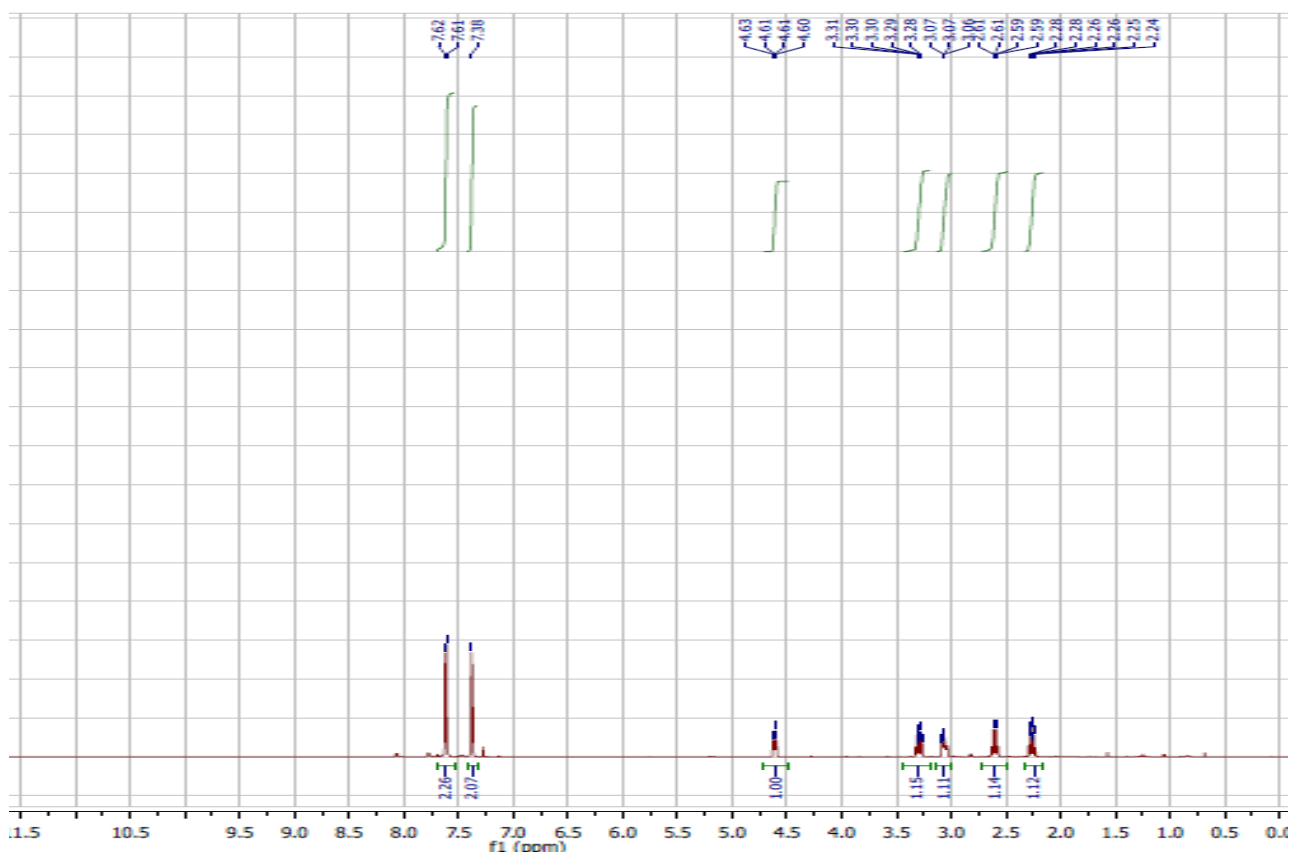

2-(4-Nitrophenyl)cyclobutan-1-one (3k)

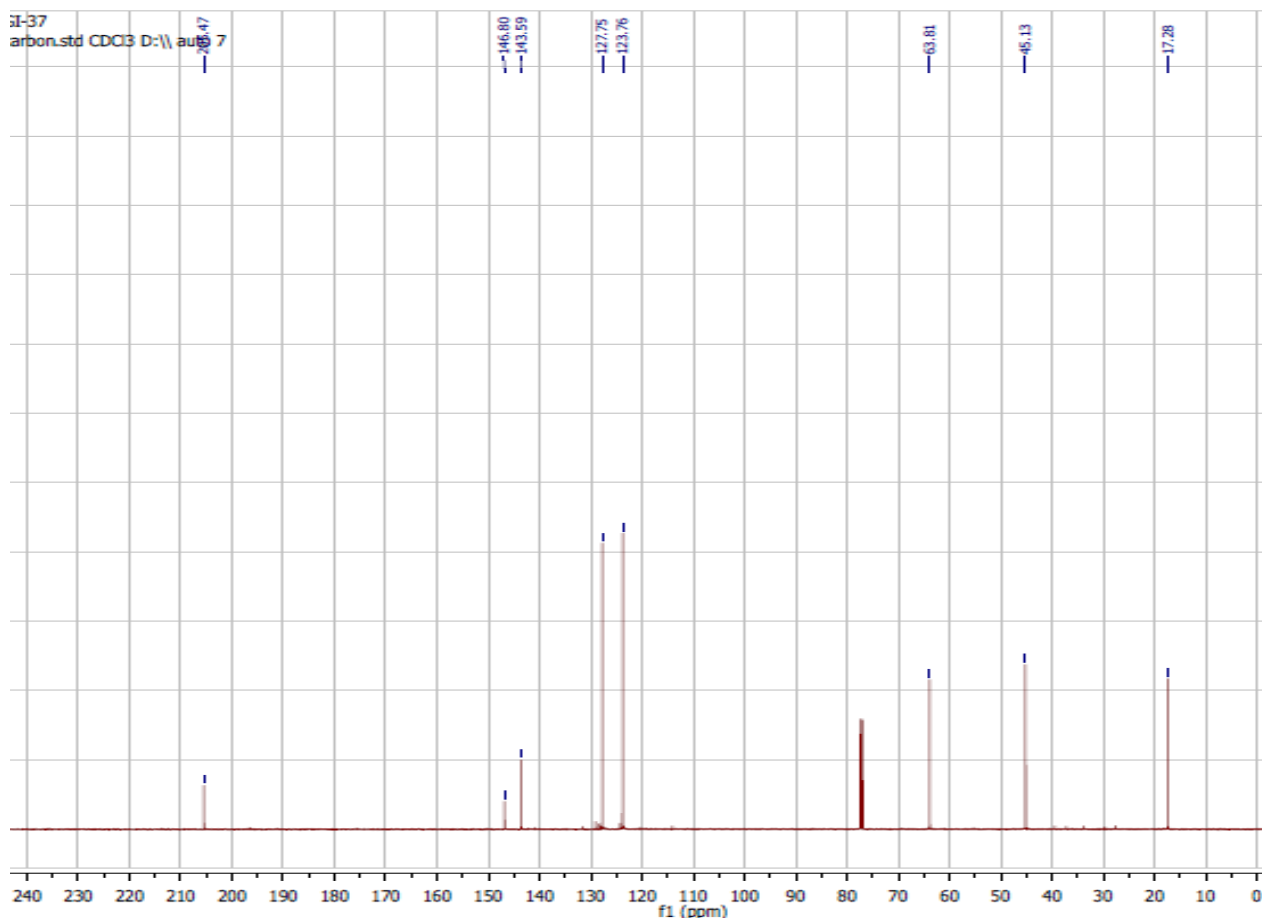
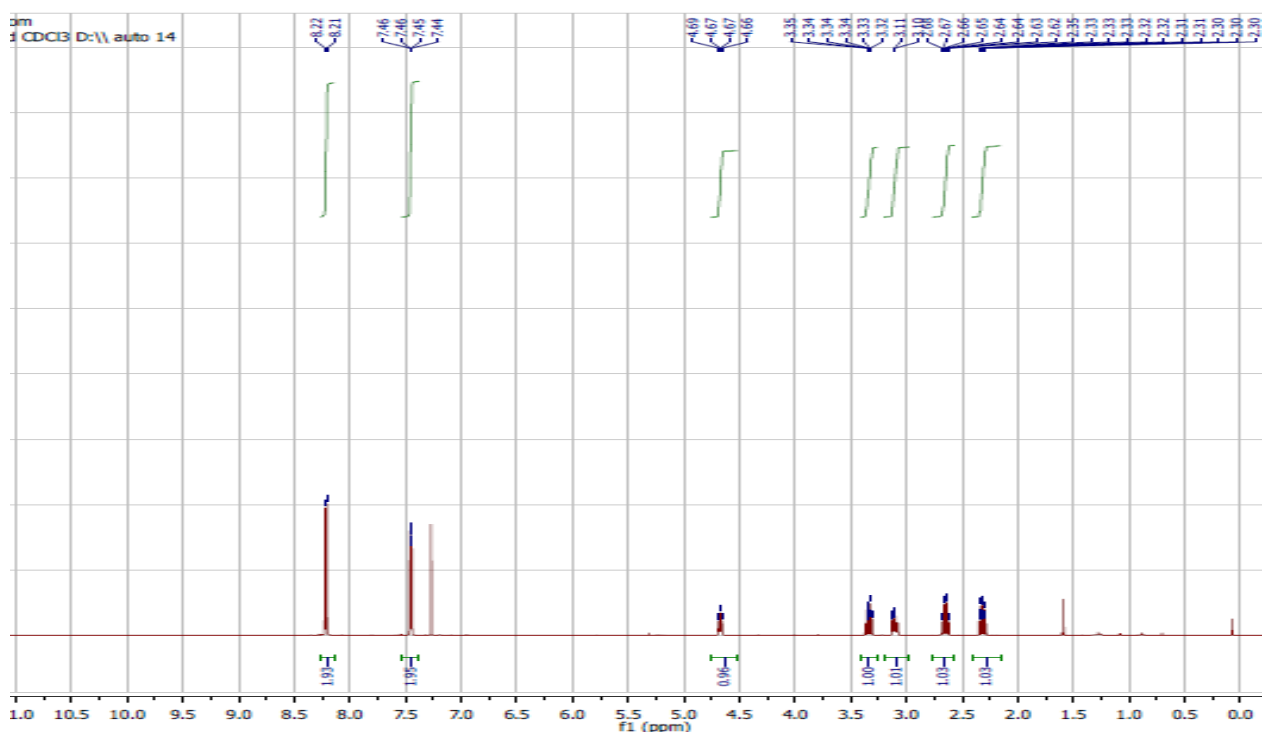

Ethyl 8-(2-oxocyclobutyl)octanoate (3l)

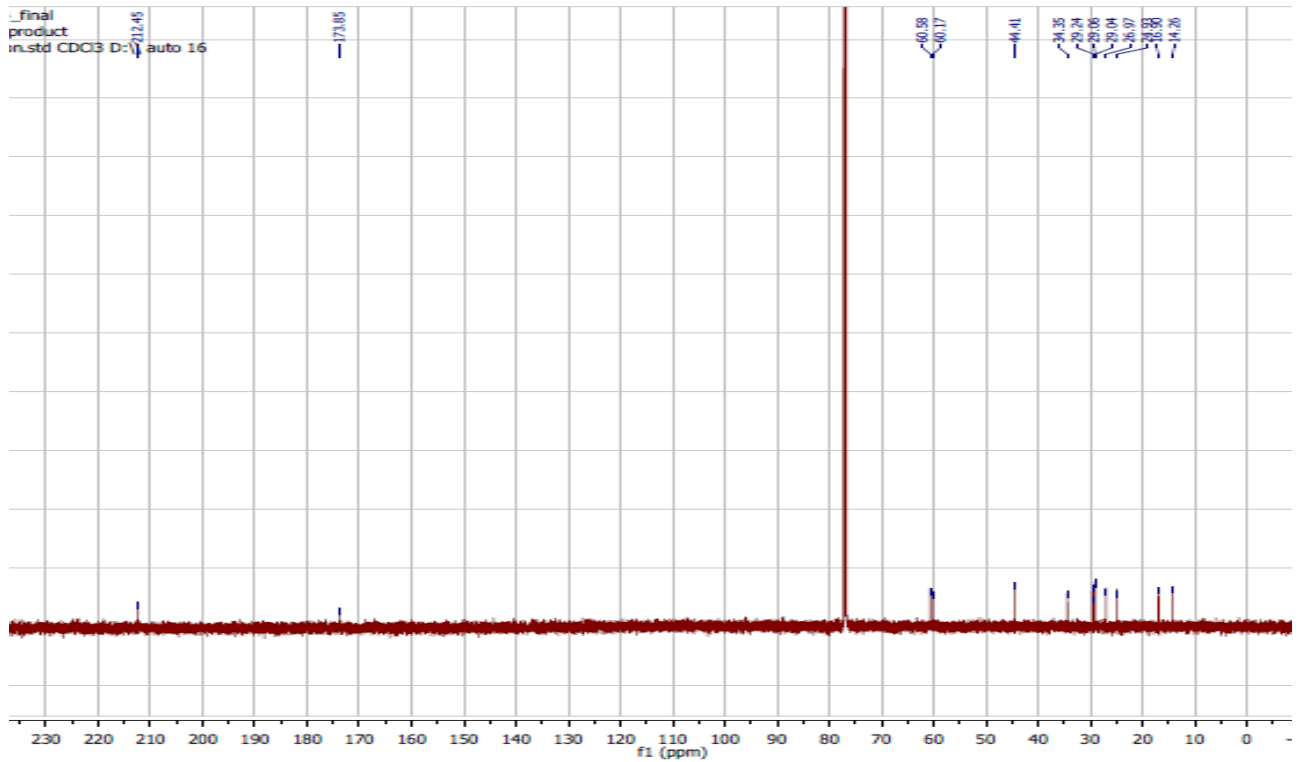
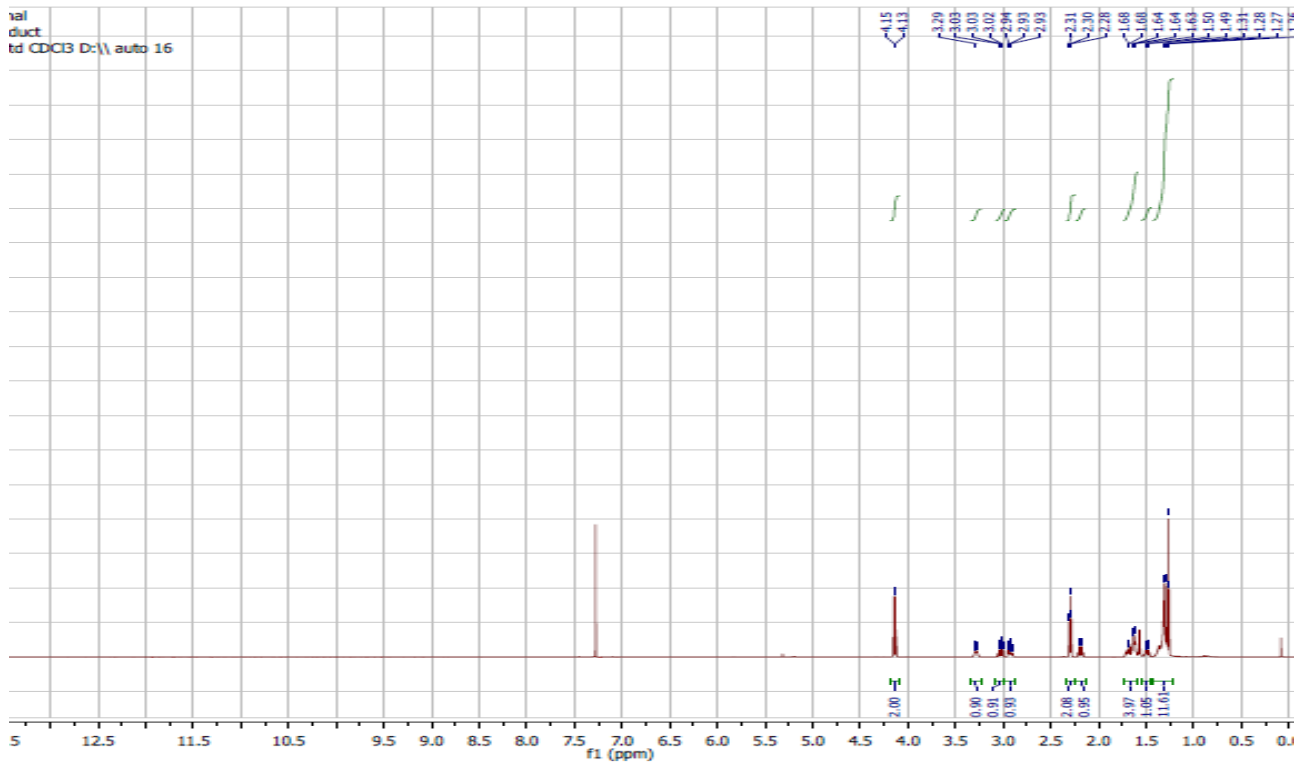

2-(9-Bromononyl)cyclobutan-1-one (3m)

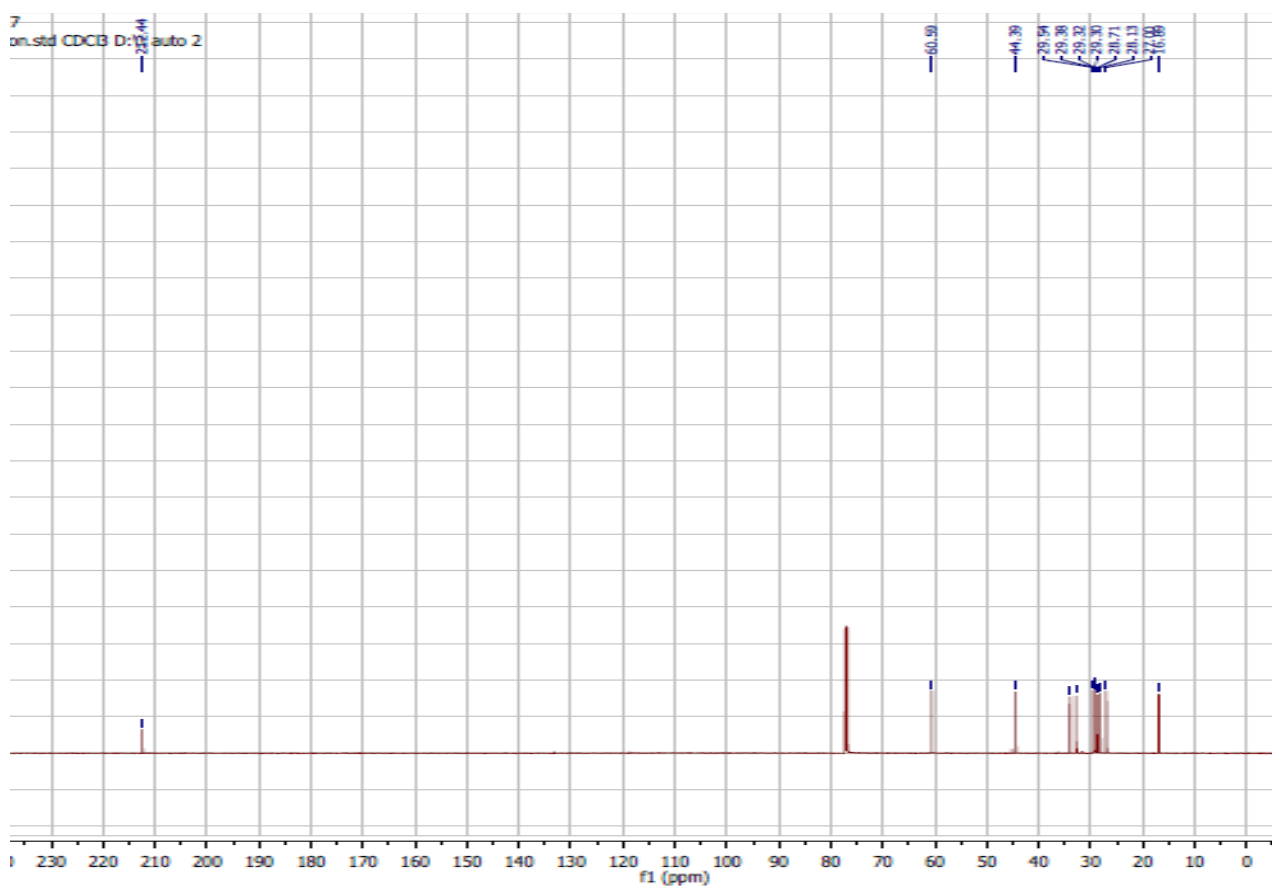
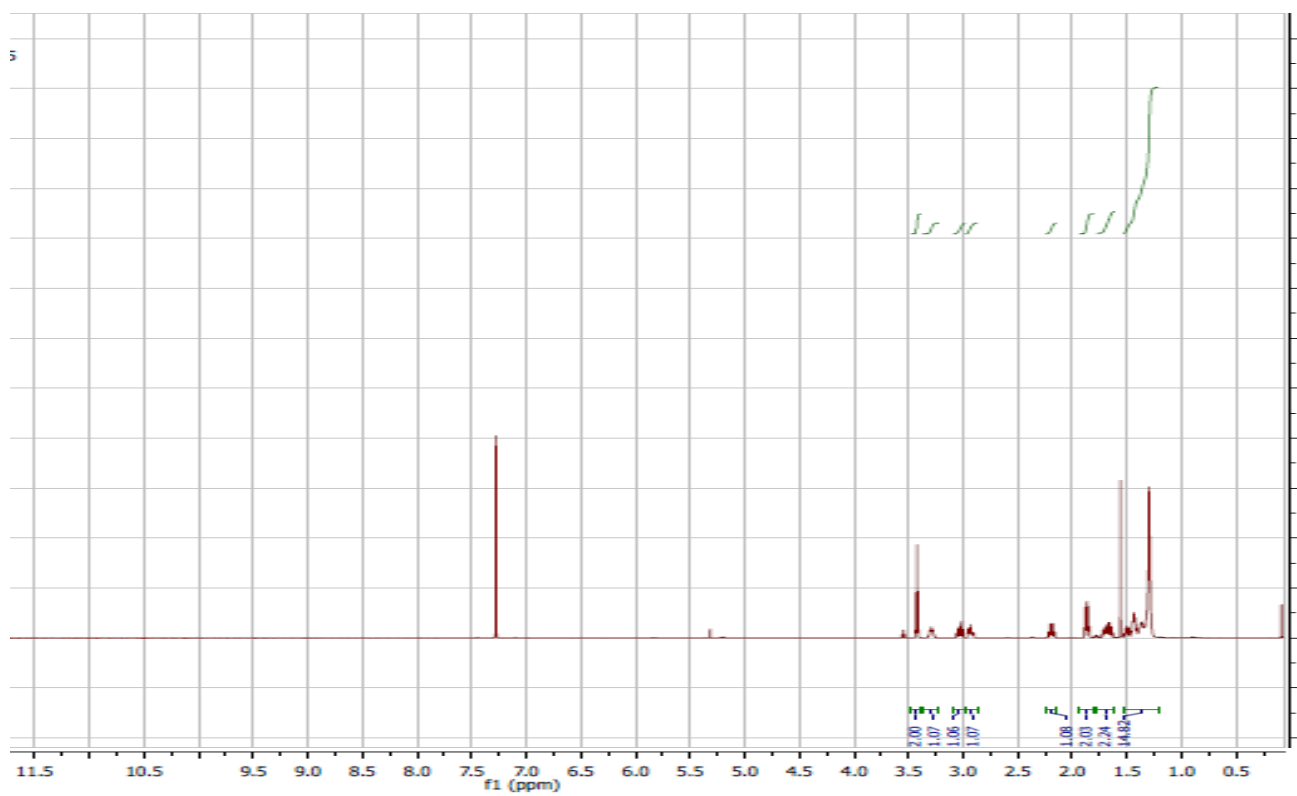

2-Hexylcyclobutan-1-one (3n)

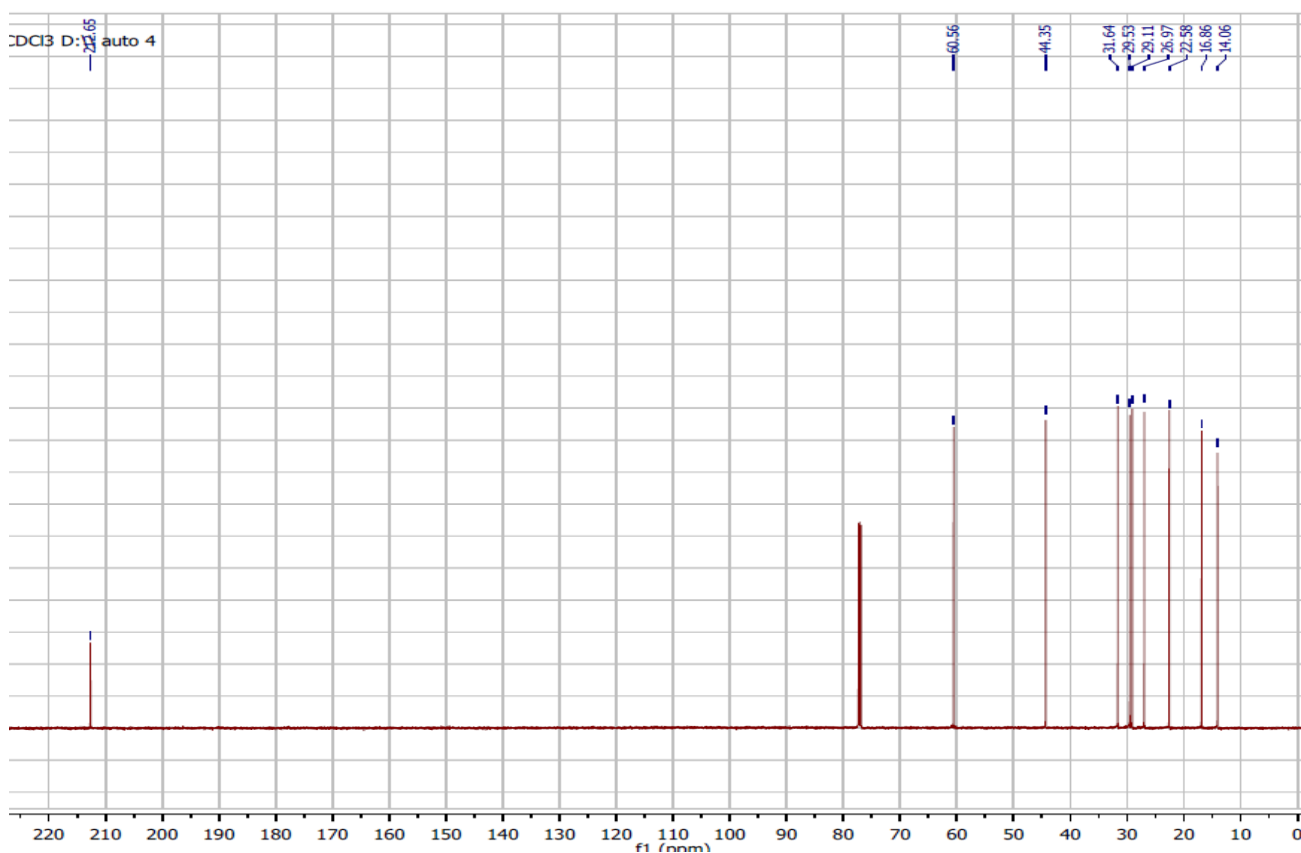
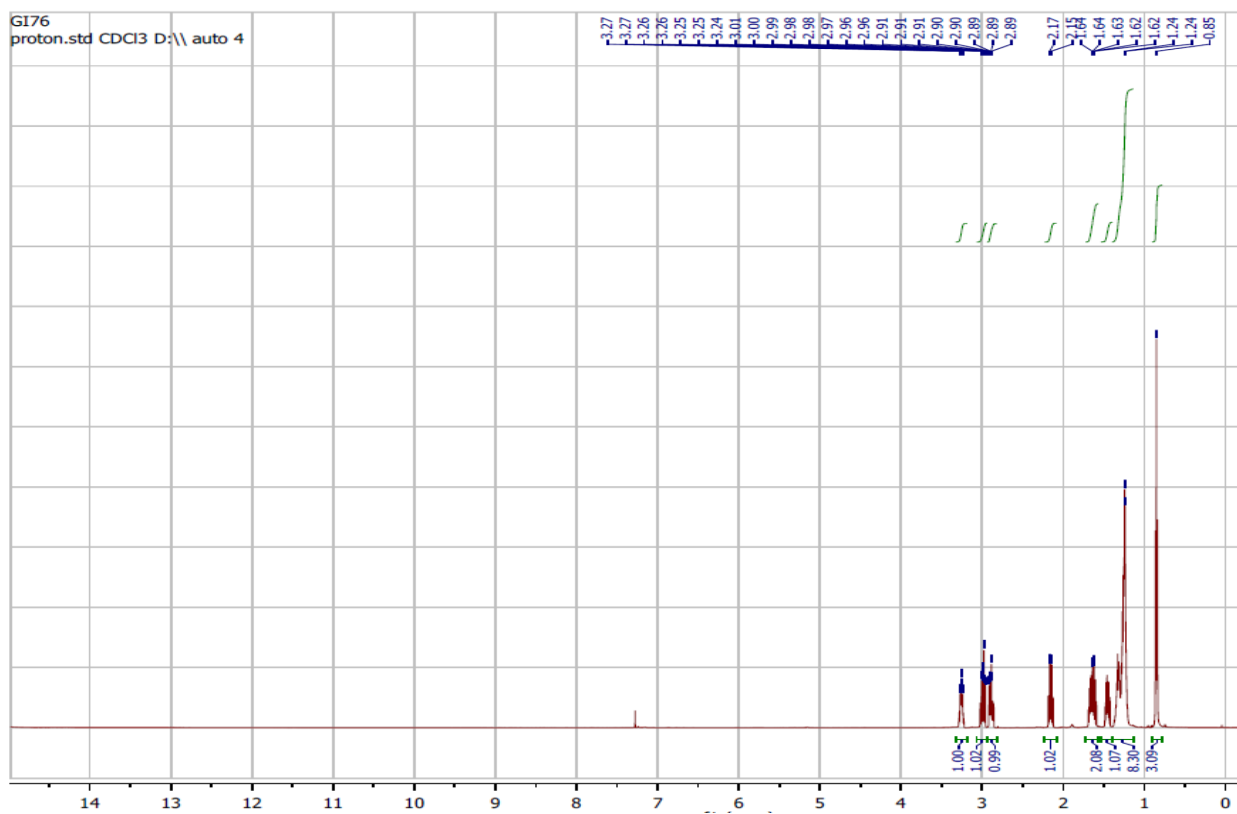

Spiro[3.5]nonan-1-one (3o)

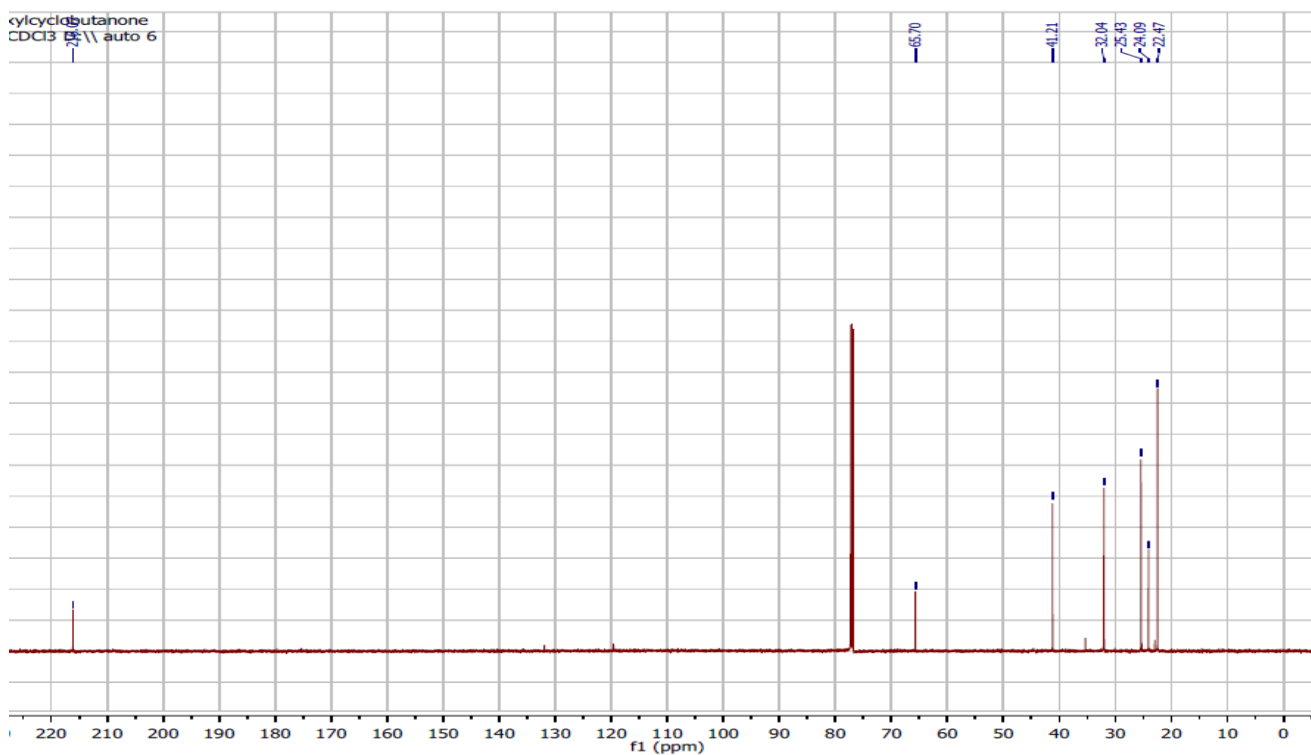
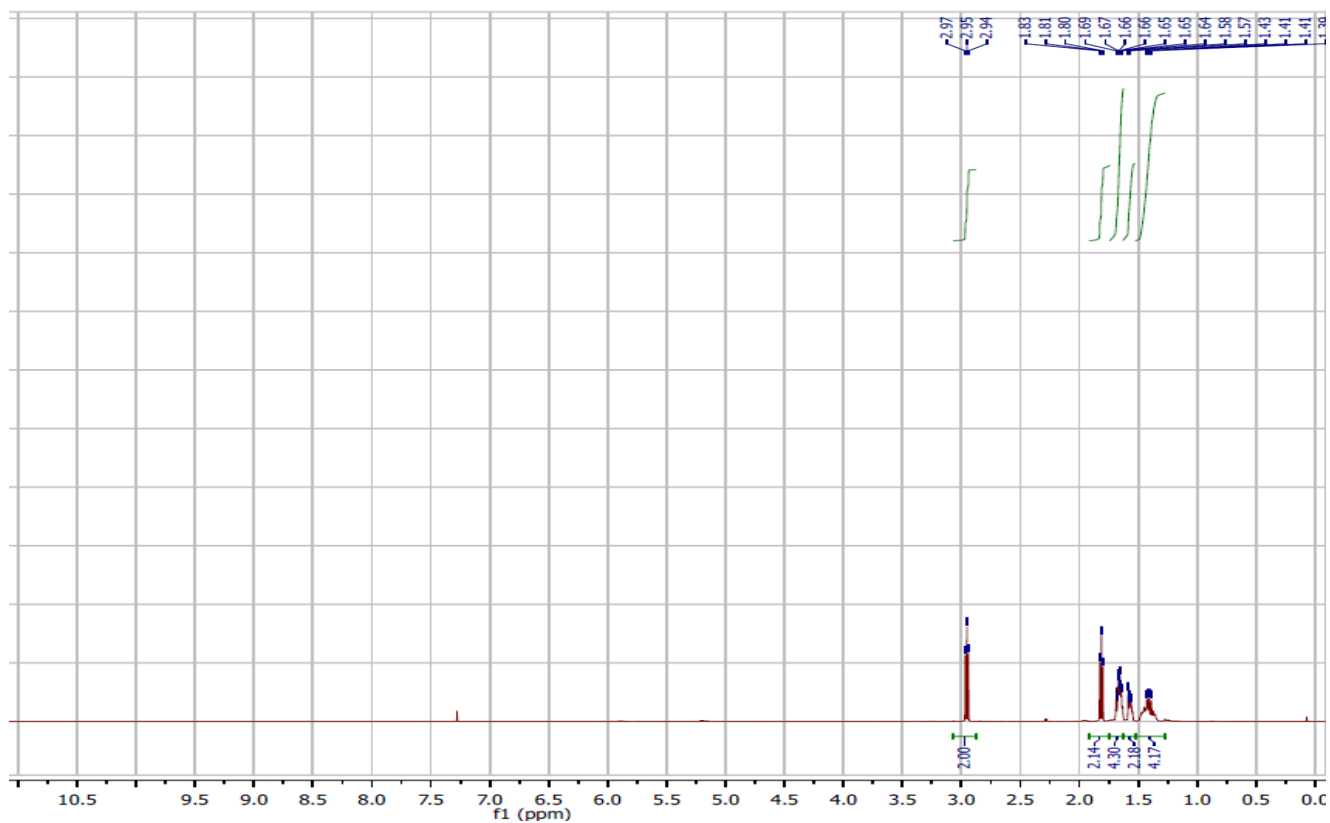

2-(Prop-2-yn-1-yl)cyclobutan-1-one (3p)

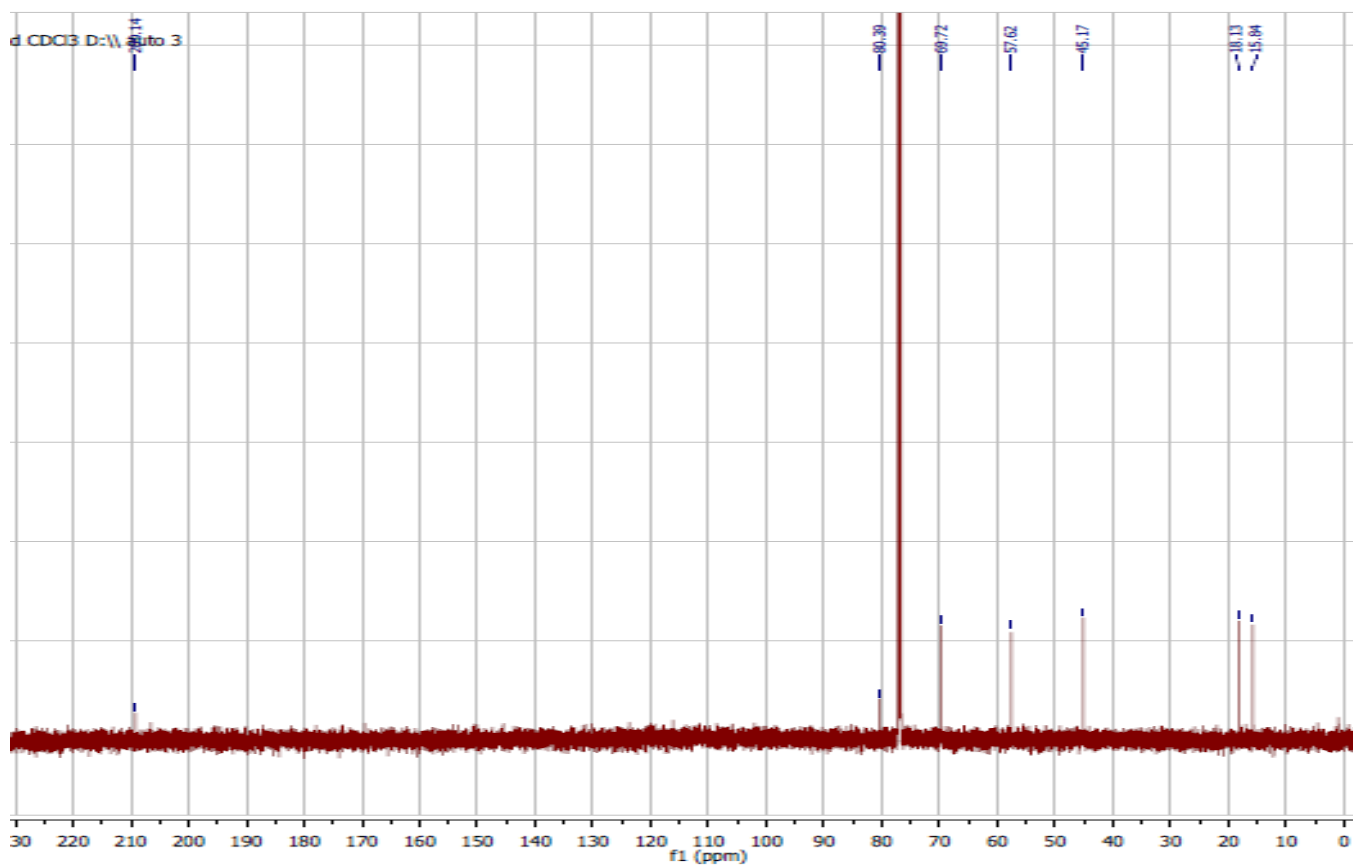
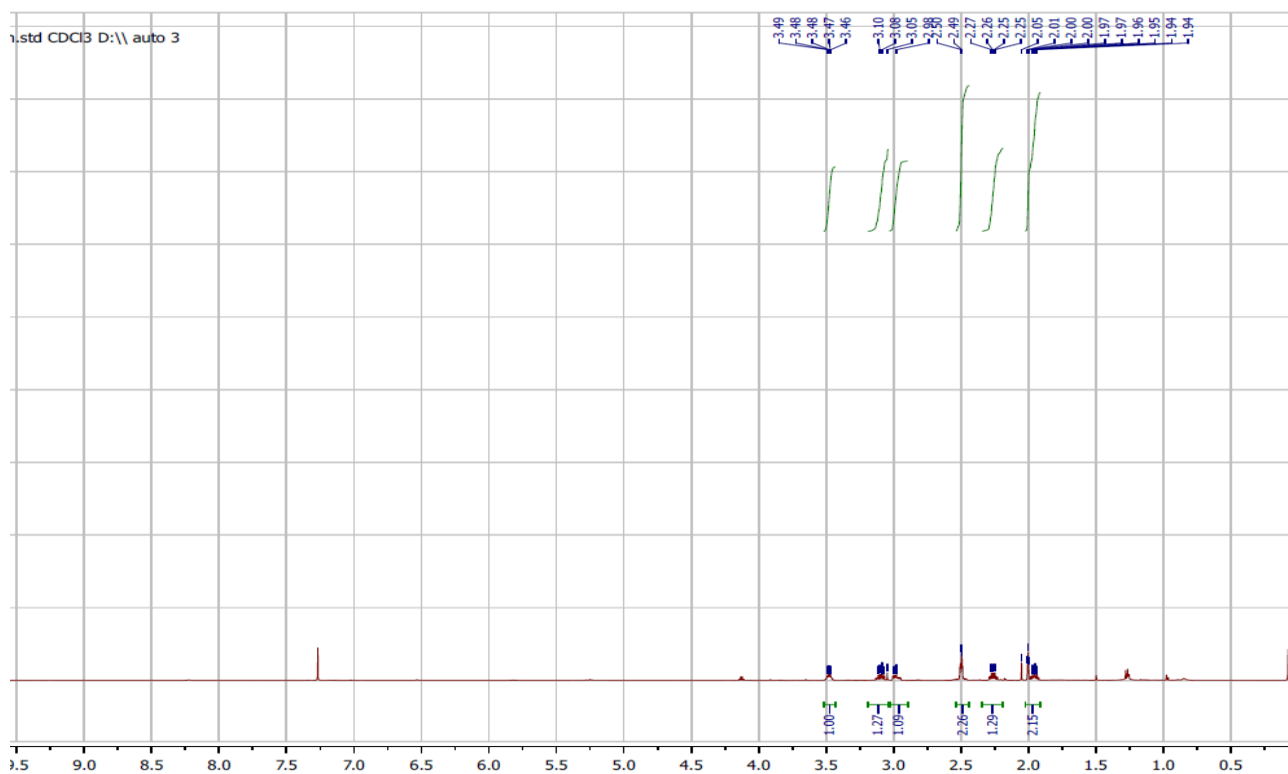

2-Benzylcyclobutan-1-one (3q)

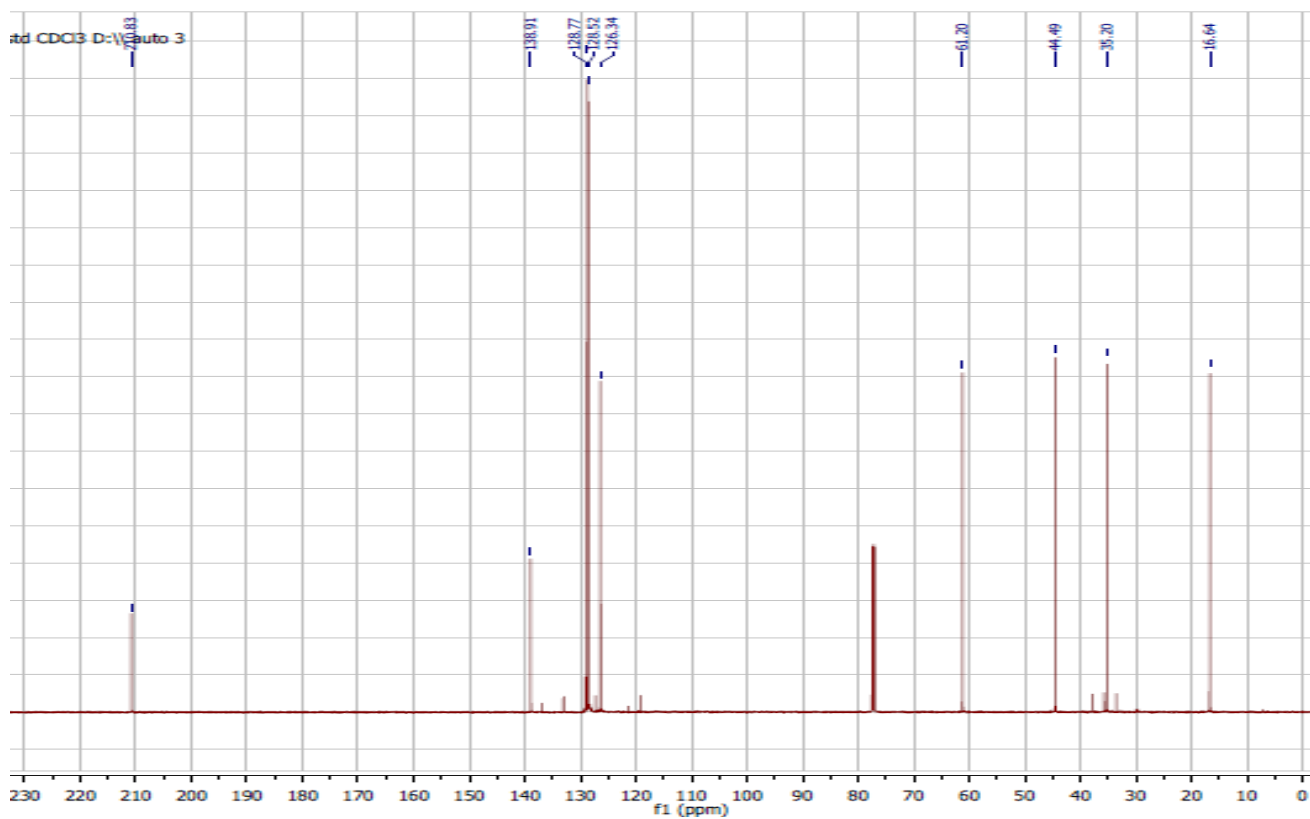
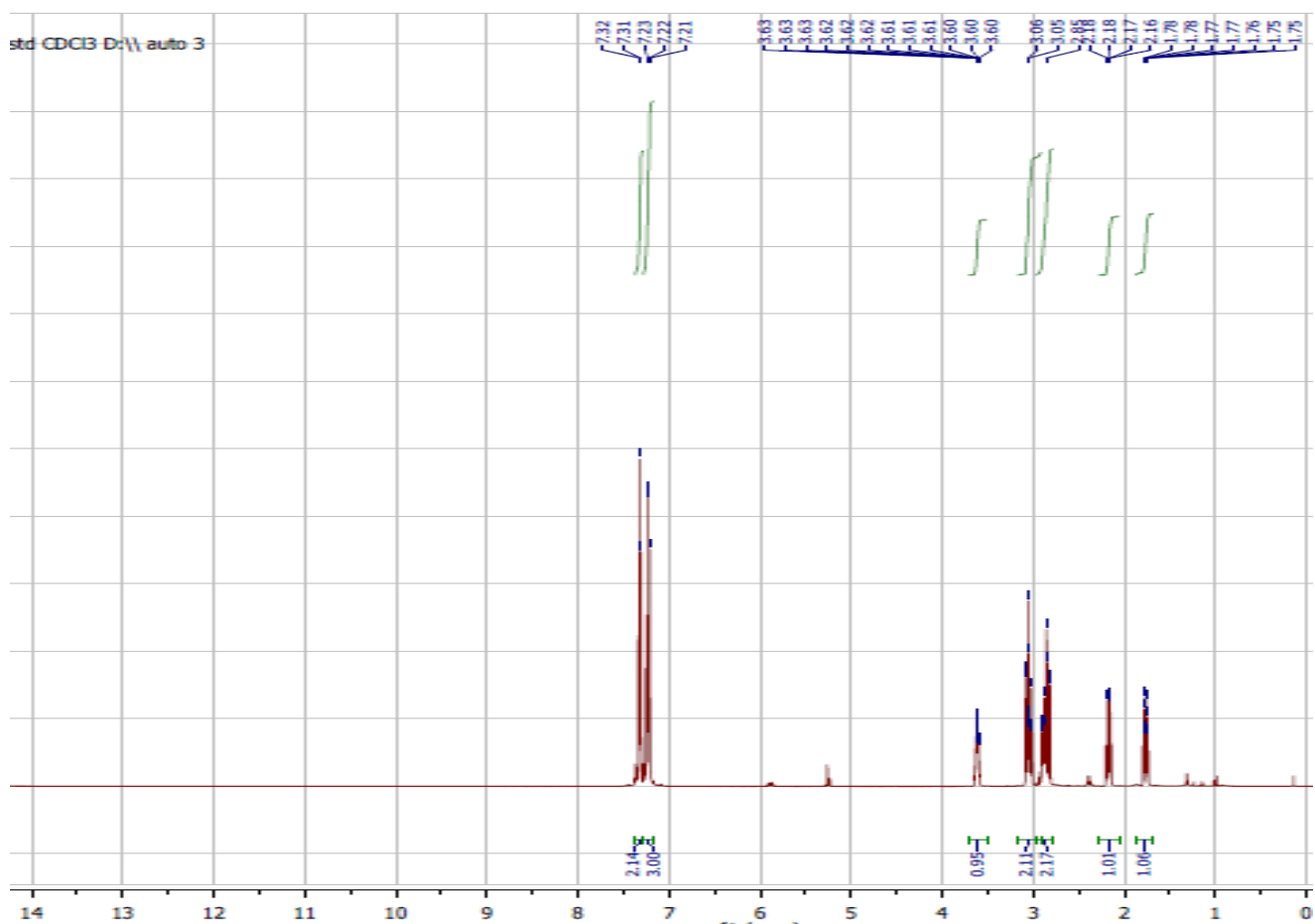

2-(2-(Pyren-2-yl)ethyl)cyclobutan-1-one (3r)

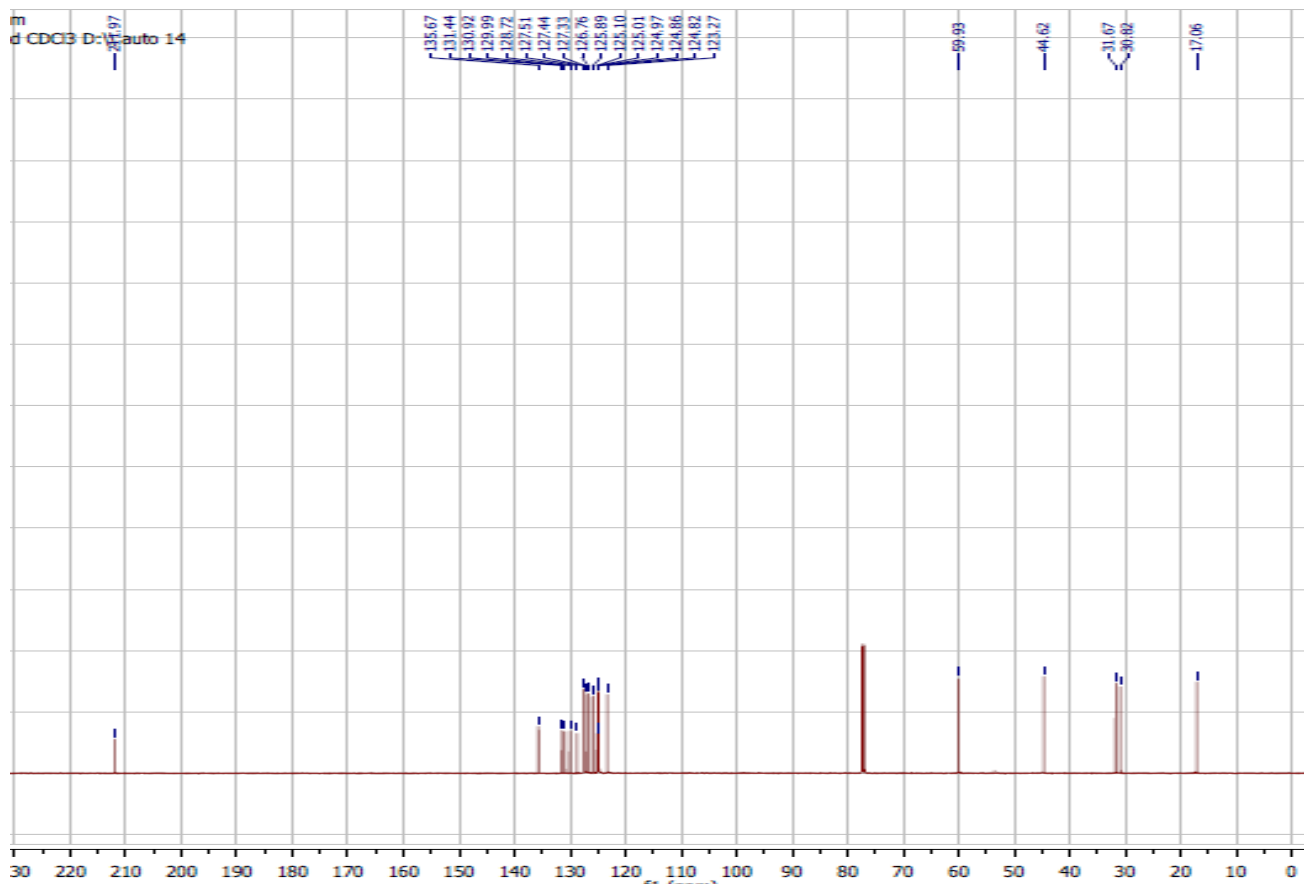
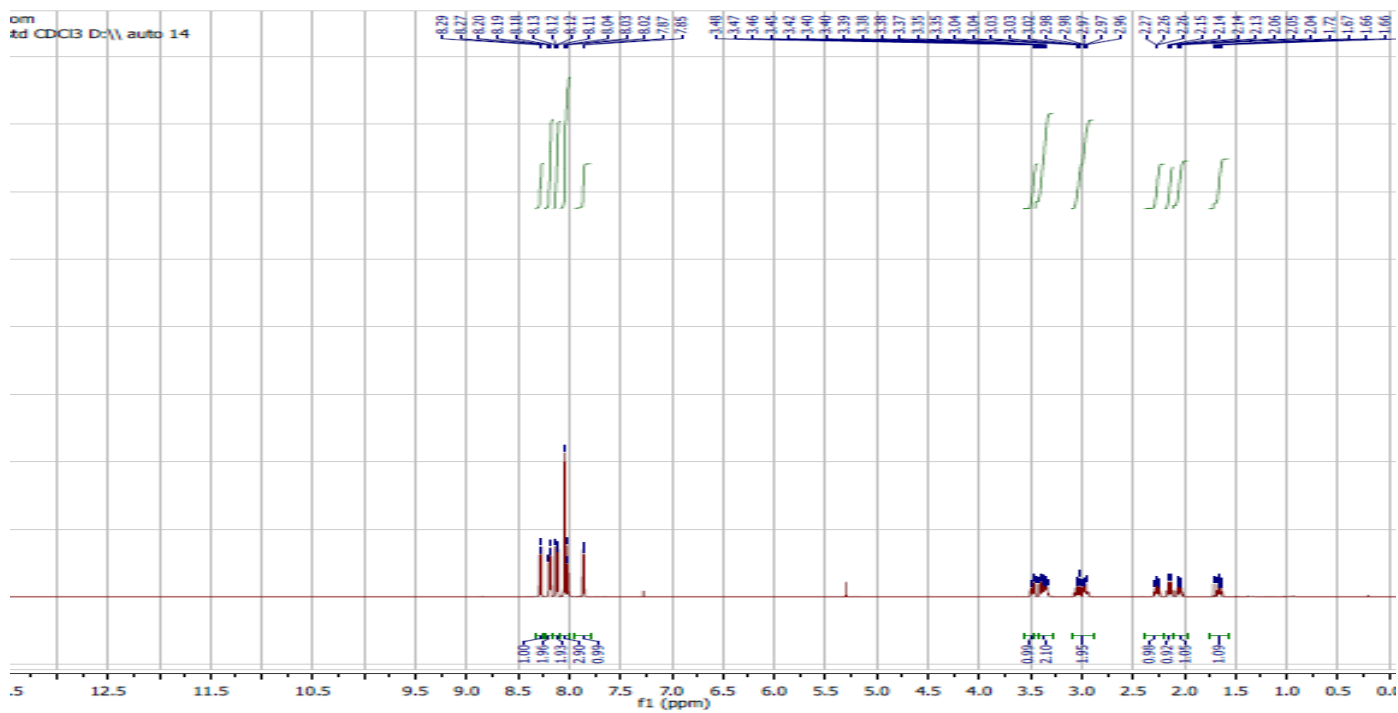

References

¹ www.vapourtec.co.uk/

² Polyzos, A.; O'Brien, M.; Petersen, T. P.; Baxendale, I. R. and Ley, S. V. *Angew. Chem.* **2011**, *123*, 1222-1225;
Angew. Chem. Int. Ed. **2011**, *50*, 1190-1193.

³ Superchi S.; Bisaccia R.; Casarini D.; Laurita A.; Rosini C., *J. Am. Chem. Soc.* **2006**, *128*, 6893-6902.